



CLINTON
COLLEGE | EST. 1894

STUDENT HANDBOOK
DIVISION OF STUDENT SUCCESS
2024-2026

MESSAGE FROM THE PRESIDENT

Greetings!

We are happy to welcome you to the Clinton College family, a college that has a rich and proud heritage. Since 1894, Clinton has been providing an academic environment that promotes intellectual and spiritual growth, moral values and leadership development. We are an accredited, four-year liberal arts institution and one of the over hundred (100) historically black colleges and universities (HBCUs) that have produced many of the nation's most outstanding leaders and pioneers in society, government, and industry.



We are located in one of the fastest growing cities in South Carolina, Rock Hill. Just a few minutes from downtown and the emerging Knowledge Park area, we are developing a world-class campus community. Rock Hill boasts of being recently voted an All-American City (2019) and soon-to-be the headquarters of the National Football League's (NFL) Carolina Panthers. We are less than 30 minutes away from Charlotte, North Carolina, a national banking and finance capital and a fast-growing cultural and residential destination.

Built on the four (4) pillars of *1. Scholarship 2. Social Change 3. Spirituality and 4. Servant Leadership*, Clinton has been producing scholars and leaders who are prepared to be agents of change in a global society for 125 years. As an institution established by the African Methodist Episcopal Zion (AME Zion) Church, we are committed to developing well-rounded graduates who are charged to make the world a better place. We challenge our students to be lifelong learners, engaged citizens, servant leaders and good stewards of the world's resources. This is a village that equips and empowers our students in the classroom, on the campus, and in the community. Here at Clinton College, we strongly believe in **"Excellence without Excuse!"** Welcome to our Village and the great legacy that makes everyone proud to be a Golden Bear!

Sincerely,

A handwritten signature in black ink that reads "Lester A. McCorn".

Rev. Lester A. McCorn, D.Min.
13th President of Clinton College

WELCOME TO CLINTON COLLEGE

Where Excellence is the Standard



**Clinton College
STUDENT HANDBOOK
2024-2026**

Clinton College
1029 Crawford Rd.
Rock Hill, SC 29730

<https://www.clintoncollege.edu/>

TABLE OF CONTENTS

Section	Page
Alma Mater	6
Forward	7
General Information	9
History of the College	12
Faith Statement	13
Mission, Vision, and Philosophy	15
Clinton College Administration	16
Campus Parking	19
Campus Phone Directory	22
Division of Business Services	24
Tuition and other Refunds	26
Financial Aid	29
Division of Academic Services	33
Graduation	38
Student Services	40
Division of Student Success	42
Student Engagement	44
• Student Government Association	44
• Student Organizations	45
• Athletics	45
• Spiritual Development Opportunities	46
• Opportunities for Community Outreach	46
Residence Life	47
Student Code of Conduct	55
Judicial Board	64
Student Complaints	66

Title IX and Sexual Harassment	70
Safety Plan	83
Evacuation Plan	87
Critical Policies	96
• GA-3: Non-discrimination policy	96
• GA-5: Family Right to Privacy (FERPA)	97
• HS-1: Health and Safety	98
• HS-4: Weapons Policy	102
• HS-7: Drug and Alcohol Prevention Program (DAAPP)	104
• IA-3: Social Media Policy	106
• SS-1: Students with Disabilities	111
• SS-6: Residence Hall Policies – Residency Requirements	112
• SS-7: Student Dress Code	113
• FA-12: Satisfactory Academic Progress for Financial Aid (SAP)	115
• FA-13: Veterans’ Benefits	121

ALMA MATER

Clinton, our dear school
For thee we reign and rule.

For thee we take our stand
to honor thee.

We'll honor, cherish thee,
As down life's path we flee,
Clinton, our dear old school

We love you so
When we enter her gate,
When we our classes take;
We pledge allegiance true
To honor Thee.

We'll honor, cherish thee,
As down life's path we flee;
Clinton our dear old school,
We love you so!

FORWARD

The *Clinton College Student Handbook* is developed and published by the Division of Student Success. It is designed to serve as a source of information outlining policies, procedures, guidelines, expectations, and responsibilities associated with being a member of the Clinton College community.

The *Student Handbook* serves as a guide and is to be used in conjunction with the *College Policy Manual*, *Academic Catalog*, and other official publications of the institution. Each student is responsible for knowing the contents of these publications. All information contained in this document is subject to change, however, every attempt is made to inform students of changes in rules and regulations when they occur. Students have the responsibility of checking with the appropriate office or visiting the website <https://www.clintoncollege.edu/> concerning the accuracy and current status of information contained in this publication and other official documents of the College.

Any questions about policies or procedures that appear in the *Student Handbook* should be addressed to the Office of Student Success, or to the area responsible for the service(s) in question.

Amendment of the Student Handbook

When changes are desirable, warranted, or demanded, Clinton College reserves the right to amend the regulations and information contained in this *Student Handbook*, with or without prior notice to students. Any amendments to the *Student Handbook* will be distributed by the Vice President of Student Success. Every student is responsible for knowledge of the regulations and information contained in this *Student Handbook*, as well as all amendments issued by the Vice President of Student Success. This publication supersedes all previous editions of the *Student Handbook*.

Student Responsibility

All Clinton College Students are responsible for knowing and complying with all Clinton College rules and regulations, both those published in the Student Handbook and verbal, or written policies set forth by the College administration. This handbook is published for the purpose of informing all Clinton College students and is intended to convey the College's expectations regarding their conduct. Rules and regulations governing student conduct are prescribed to ensure the safety and well-being of all students, and to promote the academic and social principles of the College. Clinton College grants students the privilege of attending the College on the condition that they will comply with its rules, regulations, policies, and procedures, including those in place at the time of admission and any future amendments.

Once enrolled, students are accountable for their conduct both on and off campus. This accountability applies not only during the academic term but also during vacations and periods between academic terms. Accordingly, violations of any law, statute, or ordinance; violation of

College rules; and/or conduct which discredits or draws ill repute toward the institution, may be subject to review and appropriate disciplinary action, regardless of whether the event/action/words/behavior, etc. occurs off campus or between academic terms.

At the conclusion of each semester, the College administration will review the academic and disciplinary records of students who, in the opinion of a designated College official, have failed to make appropriate adjustment to Clinton College and whose continuing enrollment is questionable. Any suspended student may return after the suspension period. The College reserves the right to deny continuing enrollment or re-enrollment to any student whose presence or conduct is deemed to be contrary to the best interests of the institution.

GENERAL INFORMATION



Facts:

Founded	1894 by The African Methodist Episcopal Zion Church
Institution Type	Private
Location	Rock Hill, SC
Enrollment	200
Colors	Gold, Black, Maroon
Degrees	Associates and Bachelors
Mascot	

Logo



Clinton College Equal Opportunity Statement

Clinton College is an Equal Opportunity educational institution and is an Equal Opportunity/Affirmative Action employer.

Accreditation

Clinton College is accredited by the Transnational Association of Christian Colleges and Schools (TRACS) as a Category II institution authorized to offer certificates, associates degrees, bachelor's degrees, and distance education. TRACS is recognized by the United States

Department of Education (ED), the Council for Higher Education Accreditation (CHEA), and the International Network for Quality Assurance Agencies in Higher Education (INQAAHE). Questions about the accreditation of Clinton College may be made in writing to:

Transnational Association of Christian Colleges and Schools (TRACS)
P.O. Box 328
Forest, Virginia 24551
Phone (434) 525-9539
email: info@tracs.org

Memberships

NAFEO – National Association for Equal Opportunity in Higher Education
CHEA – Council on Higher Education Accreditation
ACE – American Council on Education
CACRAO – Carolina Association of Collegiate Registrars and Admissions Officers
SASF AA -Southern Association of Student Financial Aid Administrators
York County Chamber of Commerce
NACUBO – National Association of College and University Business Officers
SACUBO – Southern Association of College and University Business Officers
ABACC – Association of Business Administrators of Christian Colleges

Campus Hours of Operation

Administrative Offices

Monday - Friday 8:30 a.m. - 4:30 p.m.

Digital Library and Learning Commons

Monday - Friday 8:30 a.m. - 9:00 p.m.
Saturday & Sunday 10:00 a.m. - 5:00 p.m.

Student Center

Monday - Friday 8:30 a.m. - 10:00 p.m.
Saturday & Sunday 10:00 a.m. - 12:00 p.m.

Policies

All colleges and universities have policies for faculty, staff, students, visitors, and their Board of Trustees. A policy is a statement of management philosophy and direction, established to provide guidance and assistance to the college community in the conduct of college affairs. A college policy:

- Is a governing principle that mandates or constrains action,
- Has institution-wide application,
- Changes infrequently and sets a horizon for the future,

- Helps ensure compliance with applicable laws and regulations,
- Reduces institutional risk, and
- Is approved at the executive levels of the college (the President, Cabinet, Vice-Presidents), and the Board of Trustees

The Clinton College Policy Manual is provided in a searchable format on the Clinton College website. Many of the policies for students are referenced throughout this handbook and particularly relevant policies are summarized or reproduced in their entirety in stand-alone sections or in the last section of this handbook: *Critical Policies*.

HISTORY OF CLINTON COLLEGE

Clinton College was one of several schools established by the African Methodist Episcopal Zion Church, to help eradicate illiteracy among freedmen during Reconstruction. The College has operated continuously for 120 years. In 1894, Presiding Elder Nero A. Crockett and Reverend W. M. Robinson founded Clinton Institute and named it for Bishop Caleb Isom Clinton, the Palmetto Conference presiding bishop at the time.

Incorporated as Clinton Normal and Industrial Institute on June 22, 1909, the school was authorized to grant state teacher certificates. By the late 1940s, the College enrolled 225 students per year and owned approximately 19 acres, along with several academic and administrative buildings and equipment valued at several million dollars. Under Dr. Sallie V. Moreland, who retired in 1994 after 47 years of stellar service, the school charter was amended to create Clinton Junior College. When Dr. Cynthia L. McCullough Russell assumed leadership, the school prepared for Transnational Association for Christian Colleges and Schools (TRACS) accreditation which the college attained in May 2013, under the tenure of Dr. Elaine Johnson Copeland.

In May of 2013, (TRACS) granted approval for the college to offer two 4-year programs: (1) the Bachelor of Arts in Religious Studies and (2) the Bachelor of Science in Business Administration. With approval from its accrediting body to offer 4-year degrees, the college changed its name from Clinton Junior College to Clinton College.

In accordance with its 120-year tradition, Clinton College offers an enriching academic climate that fosters intellectual growth, and imparts moral, ethical, and spiritual values. The school has a proud heritage as a Christian College, striving to prepare men and women to become lifelong learners, selfless citizens, and good stewards of society. To learn more about the history of Clinton College, we recommend the following book: *Clinton Junior College* by Peters, Copeland, McCullough, and Roddey, published by Arcadia Publishing in 2004.

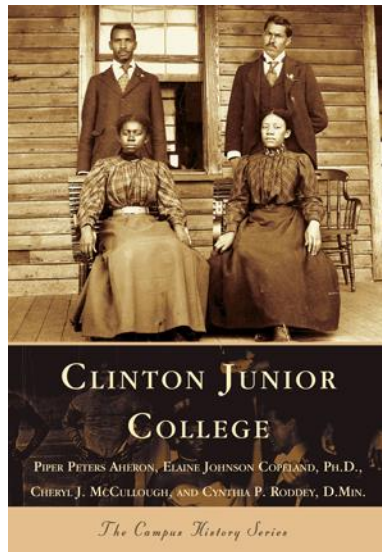

FAITH STATEMENT

College affirms and upholds the beliefs and tenets of the Christian faith as practiced by The AME Zion Church. Specifically, as enumerated by the Articles of Religion, as found in the Book of Discipline of The African Methodist Episcopal Zion Church and the Apostles' Creed, we assent to the following:

The Bible: We believe that the Bible is the Word of God and contains "all things necessary to salvation." We believe that it is authoritative in all matters of faith and morality. (Article V) (2 Tim. 3: 15-17).

Original Sin: We believe that sin is the "corruption of the nature of every [person] that naturally is engendered of the offspring of Adam, whereby [humanity] is very far gone from original righteousness, and of [their] own nature(s) inclined to evil, and that continually." (Article VII) (Ps. 51:5)

The Trinity: We believe that "there is but one living and true God, ever-lasting, without body or parts, with infinite power, wisdom and goodness; the [Creator] and preserver of all things, visible and invisible, and in the unity of this Godhead there are three persons of one substance, power and eternity-the Father, the Son and the Holy Ghost." (Article I) Further, we believe that "the Son, who is the Word, the Father, the very and eternal God, of one substance with the Father, took [human] nature in the womb of the blessed Virgin; so that two whole and perfect natures, that is to say, the Godhead and humanity, were joined together in one person, never to be divided, whereof is one Christ, very God and very man, who truly suffered, was crucified, dead and buried, to reconcile His Father to us and to be a sacrifice, not only for original guilt, but also for the actual sins of humanity. (Article II). We further affirm that "the Holy Ghost, proceeding from the Father and the Son, is one substance, majesty and glory with the Father and the Son, very and eternal God." (Article IV)

Redemption: We believe that "Christ did truly rise again from the dead, and took again His body, with all thing appertaining to the perfection of human nature, wherewith He ascended into heaven, and there sitteth until He shall return to judge all humanity at the last day."(Article III)

Salvation: We believe that "we are accounted righteous before God only for the merit of our Lord and Savior Jesus Christ by faith, and not our own works or deserving. Wherefore, that we are justified by faith only is a most wholesome doctrine and very full of comfort." We further believe that the sacraments of the church are "certain signs of grace and God's good will toward us by which He doth work invisible in us, and doth not only quicken, but also strengthen and confirm our faith in Him." (Article IX, Article XVI) (Rom. 4:5, Luke 22:19, 20)

Eschatology: We believe that Jesus Christ died and was buried and "rose on the third day from whence He shall come to judge the quick and the dead" at the last day. (Apostles' Creed) (2 Cor. 5:15, John 11:25, 26, Acts 10:42, John 12:48)

Ecclesiology and Ecumenism: We believe that the church is the visible expression of the body of Christ in the world and is a universal collection of believers serving and worshiping under the banners of different denominations.

MISSION, VISION, AND PHILOSOPHY

Mission Statement

The Mission of Clinton College is to create a holistic environment that cultivates an inclusive community of students, faculty, staff, and administrators who are prepared to excel in academic achievement; experience moral and spiritual growth; and demonstrate positive and effective leadership skills as lifetime citizens in a global society.

Vision Statement

Clinton College will be nationally recognized as an affordable institution of higher education that develops career-ready professionals and informed citizens of a global community who continuously influence and impact the international society as transformative leaders and participants.

Core Values

Scholarship. Clinton College promotes intellectual freedom and curiosity, critical and creative thinking, and visionary inquiry, with integrity being the underlying foundation in all endeavors.

Servant Leadership. Clinton College serves the community and society by respecting, promoting, and supporting the well-being and worth of all people and the communities to which they belong pursuant to practices, policies, and innovations that foster sustainability in the effective management of our human, environmental and financial resources.

Spirituality. Clinton College, founded as a Historically Black College, is grounded in the rich religious tradition of the African Methodist Episcopal Zion Church and is committed to the development of the human spirit in its many forms, and personal ethics through dialogue, inquiry, service, introspection and self-awareness experiences.

Social Change. Clinton College respects the dignity of every individual and promotes responsible citizenship and civic engagement, serving as an advocate for equality and social justice on the local, state, national, and international levels and empowers others to do the same.

Philosophy of Education

Since its founding in 1894, Clinton College has strived to offer an education to those who may not have the opportunity to pursue higher education. Founded by the Christian Education Department of the African Methodist Episcopal Zion Church, the college has historically served a diverse population in terms of academic preparation and financial resources. Many students who come to Clinton College come because of limited financial resources and others come because of inadequate academic preparation. The College serves those who excel academically and those who have yet to blossom.

CLINTON COLLEGE ADMINISTRATION



The College's administration and academic operations are exercised through the Office of the Chief Executive Officer (the President); and seven operational divisions:

1. Office of the President
2. Academic Services
3. Business Services
4. Institutional Advancement
5. Institutional Effectiveness
6. Enrollment
7. Student Success

The Office of the President

The Office of the President supervises the affairs of the administrative and academic operations of the College. The functions of this office include faculty and administrative appointments; retirements from active service, designation of emeritus status, and other functions generally and customarily assigned to the office of the chief executive, and those designated by the Board of Trustees.

Academic Services

This Division of Academic Services includes educational planning, curricular administration, academic organization, faculty teaching performance and teaching effectiveness; faculty hiring, promotion and dismissal; faculty development, budget development and administration; registration and academic records; student academic appeals, certification, and recommendation

of candidates for degrees. This division includes the *Office of Records and Registration*, the *Beacon Academic Success Center*, the *Digital Library and Learning Commons*, and the department of *Online Learning and Remote Education*.

Business Services

The functions of the Division of Business Services include budget development, technology, and administration; reconciling and reporting funds received and expended; payroll administration, and auxiliary enterprise purchasing. The departments of *Student Accounts*, *Financial Aid*, *Physical Plant*, *Campus Food Services* and *Public Safety* are also included in this division.

Institutional Advancement

The Division of Institutional Advancement plays an integral role in identifying opportunities for fiscal support and marketing the college through positive relationships with external constituencies of the College and within the community.

Institutional Effectiveness

The Division of Institutional Effectiveness provides leadership to all divisions on matters pertaining to institutional research and to accreditation standards and compliance; planning, organizing, and evaluating the college's progress towards strategic goals and objectives; assessment of student learning outcomes, best practices for data collection, storage, and use; and evidence-based improvements.

Enrollment

The mission of the Division of Enrollment is to market the college, implement effective strategies that increase enrollment, assist students in the enrollment process, and prepare students to begin their college journey.

Student Success

The Division of Student Success includes the following departments: Residence Life, Counseling, Campus Ministries, Student Activities, and Athletics. Collectively, the mission of the Division is to offer diverse extra-curricular experiences and offer support services that contribute to our students' personal, academic, and professional development, while also maintaining a safe campus environment. The Division of Student Success is also responsible for enforcing student and campus policies; rules and regulations defined in the student handbook. The broad goal of each department is to work collaboratively to ensure all students have an optimal collegiate experience.

Locations

The buildings and locations of departments and offices are shown in the table below:

Slade Administration Building
Academic Services
Records and Registration
Business Services
Financial Aid
Counseling

Gymnasium
Athletics
Digital Library and Learning Commons
Admissions
Snipes Building
Student Center
Student Engagement
Fisher Building
Dean of Students
Student Support Services
Student Success

PARKING INFORMATION



Responsibility

It is the responsibility of each student, faculty, and staff member to become familiar with campus parking policies, including authorized parking locations. The campus map designates where students, faculty, staff, and visitors are permitted to park. Clinton College assumes no responsibility or liability for fire, theft, damage, or loss of any vehicle or item left therein. If any owner or operator of a vehicle receives a parking ticket, it is the responsibility of that individual to respond to the ticket, and to properly identify themselves to Clinton College security staff members when in discussions about the ticket.

Enforcement

Parking enforcement is the responsibility of Clinton College Security and Facilities Department. Parking regulations and enforcement are in effect 24 hours a day, 365 days per year. Security officers may require identification from any person(s) on campus. Refusal to comply may result in the issuance of a citation, a towed vehicle and/or notification of the Rock Hill Police Department. Parking tickets are not issued arbitrarily. When security officers issue parking tickets, they have observed a problem that warrants communication with the registered owner or operator of the vehicle.

Signage

Parking signs are displayed throughout campus to designate approved “student” parking locations.

Vehicle Registration/Permitting Process

All vehicles parked on campus must be registered with the Office for Business Services. Vehicles must be registered before a parking permit can be purchased. Owners or operators of any vehicle must be able to show a valid registration and evidence of current insurance coverage, upon request, to be on campus. Students are not allowed to park on campus after the course registration deadline without a valid parking permit, with the exception of students who are in the process of course registration and awaiting the issuance of a permit.

Permits¹

Any vehicle parked on campus (i.e. owned or used by any student, faculty, or staff member), must display a valid parking permit. Parking permits may be obtained through the Office of Business Services.

Student Permit. Students who plan to park on campus must purchase park permit. Parking permits are \$25 per vehicle and can be purchased in the Office of Business Services.

Medical Permit. Medical permits are available for students, faculty, and staff who have restricted mobility that limits their ability to walk long distances due to an illness, injury or other medical reason. Medical permits are temporary and are valid only for the duration.

Permit Placement. Parking permit decals must be applied to the driver's side window, farthest to the rear. Faculty and Staff parking permit decals must be displayed from the rear-view mirror. If you have questions about placement of a parking permit or evidence of an illegally attached permit, contact Facilities, Campus Security of the Office of Business Services/Services.

Lost, Stolen or Damaged Permits. If a vehicle is sold, or involved in an accident that renders it inoperable, the old permit must be removed and returned to the Office of Business Services/Services. A replacement permit will then be issued without additional cost. Lost or stolen permits must be reported to security immediately. Failure to do so may result in the owner's vehicle being towed from campus, a fine and/or a referral to the Student Conduct Committee.

Altered Permits. Altering a parking decal is a violation of the college's parking policy and may result in the vehicle being towed, along with a fine to the owner and/or referred to the Student Conduct Committee. Altered permits will be confiscated and the owner of the vehicle will lose parking privileges for the remainder of the academic year.

Prohibited Parking Areas

Parking is prohibited in driveways, walkways, building exits, fire lanes, on grass or any place that would prevent access to emergency vehicles. Any vehicle parked in prohibited areas will be towed, with or without notice, and at the owner's expense.

Any vehicle parked in an unauthorized space may receive a parking ticket and/or the vehicle may be towed without warning or notice. Students with valid parking permits, may park in

¹ The College does not guarantee parking will be available. A permit is merely permission to park legally in one of the authorized parking lots.

faculty/staff parking areas between the hours of 5 p.m. and 7 a.m. during weekdays and 5 p.m. Friday to 7 a.m. Monday over weekends.

Parking Over Holiday Breaks

Students who wish to leave their vehicle on campus over any holiday break must contact Security to make appropriate arrangements. Students who are on campus during break may park in designated student spaces. Vehicles left in any other parking lot after this timeframe, may be ticketed and/or towed without warning or notice.

Conducting Vehicle Repairs

Minor maintenance (such as replacing a tire or battery, or other wear and tear components designed for easy swap out replacement) are allowed. Vehicles shall not be raised or suspended on jacks or stands for the purposes of working underneath the vehicle and no vehicle shall be left jacked up unattended.

Facilities and Maintenance Needs

Any person using campus parking is expected to move their vehicle promptly during periods of required maintenance. Notices will be placed in all dorms and sent out via e-mail. These notices will state the warning or notice.

Parking Related Notices

General parking announcements will be sent via e-mail. Parking announcements will be titled either “**Parking Notice**” or “**Urgent Parking Notice.**” Individuals with parking permits are responsible for reading all parking notices and remaining in compliance with any directives outlined in the notices. If assistance is needed campus security may be contacted via phone at (803) 371-9665.

CAMPUS PHONE DIRECTORY

1	Admissions/Financial Aid/Records and Registration	Ext.
	Director, Admissions Department	8190
	AVP Enrollment	8189
	Director, Financial Aid	8163
2	Office of President	
	Executive Assistant to the President	8149
	Vice President of Institutional Effectiveness	8156
3	Academic Services	
	Vice President, Academic Services/Academic Dean	8151
	Receptionist/Administrative Assistant	8150
	Director of Records and Registration	8152
	Beacon Academic Success Center	8167
	Director, Student Support Services	8168
	TRiO Data Specialist/Administrative Assistant	6388
	Academic Learning Specialist	8193
	Student Success Coach	8172
	Director, Digital Library and Library Commons	8158
	Library Technical Assistant	8160
4	Business Services/Human Resources/Student Accounts	
	Vice President, Business Services	8154
	Student Accounts Manager/Accounting Assistant	8155
	Director, Financial Aid	8163
	Information Technology Specialist (IT)	6387
5	Office of Institutional Development	
	Vice President, Institutional Advancement	8181
	Director, Communications	8145
	Director, Alumni Engagement/Sponsored Programs	8166
6	Student Success	
	Vice President Student Success /Dean of Students	8161
	Director, Student Activities	8162
	Campus Minister	8169
	College Counselor	8173

7	Residence Life	
	Area Director/ Cauthen Hall	8183
	Area Director/Marshall Hall	8184
8	Athletics	
	Athletic Director/Men's Basketball Coach	8171
	Women's Basketball Coach	8172
9	Building and Grounds	
	Superintendent, Facility Services	8174
	Café	8177
	Public Safety	803-371-9665

BUSINESS SERVICES



The Division of Business Services includes the departments of *Student Accounts*, *Financial Aid*, *Physical Plant*, *Campus Food Services* and *Public Safety*. The functions of Business Services include, among others, budget development, technology, and administration; reconciling and reporting funds received and expended; payroll administration, and auxiliary enterprise purchasing.

Payment of Tuition and Fees

Tuition and Fees are assessed on a semester basis. Clinton College requires all students to pay their account balance in full at the time of registration. If your account balance is not paid in full at the time of registration, you may be dropped from your classes. In addition to money orders, the College also accepts MasterCard, American Express, VISA, and Discover cards.

Methods of Payment

Online (Campus Café)

Student account balances must be paid by credit card, or debit via the student payment portal on Campus Café, accessed through the Clinton College website. Balances must be paid in full prior to the first day of class. Late registration will result in a late registration fee.

Financial Aid or Military Benefits

Students are strongly encouraged to complete Financial Aid forms at least one month before registering for classes to allow for the necessary processing time. If your Financial Aid forms are not complete, you are responsible for paying the full balance due. Once Financial Aid is processed, a credit balance (refund check) will be issued for any account with a credit balance.

If a student anticipates military benefits, the student must submit verification of military benefits or pay the balance in full to hold their seat in registered classes since funding does not disburse to your student account until after the start of the term and amounts may vary depending on your enrolled credit hours. Students are responsible for any charges not covered by financial aid or military benefits. Failure to pay remaining balances could result in classes being dropped. (See Policy FA-13: Veterans Benefits.)

Company Sponsored Billing Agreement

Sponsored Billing is available for students whose employers will pay for their tuition and fees within 30 days of the start of the term, regardless of grades or class attendance. A letter from the sponsor on company letterhead must be submitted to the Office of Business Services as verification the payment for the student's tuition and fees will be made by their employer. The letter must include the anticipated payment amount for tuition and fees. Students are responsible for any charges not covered by their employer. Please contact the Office of Business Services/Student Accounts for any questions about Sponsored Billing.

529 Plans

If a student participates in a 529 plan, please contact the Business Services Office immediately after registering for classes. Inform the Student Accounts Manager that you are using a 529 plan. The Student Accounts Manager will place a protective hold on your student account to allow time for the check from the 529 plan to be sent to the College. Students are responsible for contacting the provider and requesting a check be sent to the College to pay for tuition.

- The check should be made payable to "Clinton College"
- The check must include the student's name and student ID number
- The check should be made for no more than the cost of tuition and fees on the student's account for the current term

Students are responsible for any charges not covered by their 529 plan. Failure to pay remaining balances could result in classes being dropped.

Cancellation of Registration for Non-Payment

Clinton College monitors and drops students from classes due to non-payment of tuition and fees. The *drop for non-payment process* is intended to ensure students are successful in fulfilling their financial obligation to the College, which in turn frees students to succeed in their educational journey.

Note: The Office of Business Services will not accept cash payment or personal checks. All payments must be via credit card, money order or cashier's check.

TUITION AND OTHER REFUNDS

Tuition Refund

As described in detail in Policy BS-2: Tuition Refund, there are guidelines and processes for requesting a tuition refund. If for any reason a student finds it necessary to reduce their overall credit load by: (a) withdrawing from school for the entire semester or (b) dropping a course(s), tuition and related fees charged will be refunded to the appropriate party (i.e., agency, lending institution, and/or student) as dictated by federal and state regulations. Refunds will take approximately 3-4 weeks to process. The amount of the refund will be based on the official withdrawal date. After refunds have been recorded, any credit balance in the student's account will be processed and released based in the following order:

1. Financial aid awards, including Federal Direct loans will be adjusted to comply with state and federal regulations.
2. Monies paid through third-party contractual agreements will be refunded to the granting agency.
3. Remaining balances, if any, will be refunded to the student via check.

The amount of refund is determined according to guidelines presented below:

Withdrawal Date	Percent of Refund
Prior to first day of class	100%
Between 1st and 5th day of class	75%
Between 6th and 10th day of class	50%
Between 11th and 15th day of class	25%
After the 15th day of class	0%

Eligibility for Refund

The refund policy applies only under the following conditions: (a) the student completed the formal withdrawal process and (b) The effective date for withdrawal is the date recorded in the academic calendar as the official withdrawal date. If a student does not attend or discontinues attendance without completing and submitting drop or withdrawal paperwork, the student will not receive a refund.

Voluntary and/or Administrative Withdrawal

All students must officially withdraw from classes to receive a full or partial refund. To officially withdraw, a student must complete a Withdrawal Form and return it to the Director of Registration and Records whose office is located in the Main Office of the Administration Building. Students must process the Withdrawal Form during the established timeframe to be eligible for refund of tuition (see schedule below). The effective date of the student- initiated withdrawal will be the date the completed withdrawal form is received in the Director of Registration and Records' Office.

Payment will be required if a student does not officially withdraw, but simply never attends class. If you are receiving Financial Aid and you do not attend (no show) or you do not meet the 10-day seat time attendance requirement, Financial Aid will be removed from your student account, and you will be held responsible for all tuition and fees. Students will be billed for classes and the debt will be processed through the College's collection procedures if payment is not received. Students who are administratively withdrawn will receive any refund due based on the official date of the administrative withdrawal.

Note: Courses will be deleted from the system for students who process the Drop/Add/Withdrawal Form during the 100% refund period and no grade will appear on the student's transcript.

Dropping below Full Time Enrollment Status

Any full-time student who drops below full-time to part-time status, after the last day for drop/add will be charged tuition, fees, room, and board at the full-time rate. For the purposes of Financial Aid, enrollment status will also be set at this time and there will be no adjustments to Federal, State, or Institutional Aid.

Refunds for cancelled classes

There is an automatic 100% refund for classes that are cancelled by the College.

Late Registration Process Refunds

Refunds for students who enter a class late and subsequently drop the course will be calculated based upon the start date of the class, not the date the student registered for the class. See the refund schedule above for details.

Credit Balance Refunds

All credit balance refunds will be issued to the student unless the student requests, in writing, that the credit balance be refunded to someone else.

Non-refundable payments

Paid registration fees, late fees and tuition payment plan fees are non-refundable. If a student withdraws from the College after payment of the fees, the paid fees are forfeited.

Other Refunds

Room and Boarding Refund Policy

The Room and Boarding Refund Policy is identical to the Tuition Refund policy:

Withdrawal Date	Percent of Refund
Prior to first day of class	100%
Between 1st day and 5th day of class	75%
Between 6th day and 10th day of class	50%
Between 11th day and 15th day of class	25%
After the 15th day of class	0%

The effective date for the boarding refund will be the date upon which the student vacates the room, the room is cleared and signed off by dorm manager; the student returns the room key and signs the room clearance form. Any residence hall damages for which the student is held responsible are applied against the dorm security deposit held by the College. When a student ceases to reserve or reside in College housing, the balance of the deposit becomes refundable if the following stipulations are satisfied: (1) the room has been inspected and cleared by the dorm manager and (2) The room clearance form has been signed by student and dorm manager. Refunds may be processed within sixty days of dorm room clearance.

Boarding Refund Policy for Commuter Students

The Boarding Refund Policy for commuter students who purchase a meal plan is the same as the tuition refund policy and the room and boarding policy for residential students.

Method of Refund:

- If you paid your bill by money order, cashier's check, or credit card, you would receive a check from the college for any refund due to withdrawal.
- If you deferred payment of your tuition and fees through financial aid, loans, or another third party, then your 'refund' will be in the form of a reduction in your liability to the college. Any remaining credit balance (refund) will then be disbursed via check from the college for any refund which you are entitled.
- Refunds from credit balances are disbursed after 14 days of receipt of financial aid, loans or other third-party funding source.

FINANCIAL AID



Office of Financial Aid

The purpose of the Office of Financial Aid at Clinton College is to provide financial assistance to students who without such aid would not be able to attend college. The mission of the Office of Financial Aid is to assist students in finding ways to pay for their college education such as scholarships, grants, student loans, and on campus employment. The Office of Financial Aid at Clinton College makes every effort to provide for the timely delivery of financial assistance to eligible students.

Clinton College participates in the following Federal Student Financial Aid Programs:

- Federal Direct Loan
- Federal Pell Grant
- Federal Supplemental Educational Opportunity Grant (FSEOG)
- Federal Work-Study Program

All award packages including athletic, academic, and outside scholarships are coordinated through the Office of Financial Aid. The total financial assistance awarded will never exceed the costs related to attending Clinton College. If a student is eligible for funds, awards from these programs will appear as credits on his/her account once his/her financial aid award is finalized.

How to Apply for Financial Aid: Initial Application

To be considered for financial aid at Clinton College, students must first apply and be accepted for admission. However, students should not wait for a notice of acceptance before submitting their financial aid application. Students are encouraged to apply for financial aid no later than October 1st or shortly thereafter. All applicants who wish to be considered for federal and state financial aid must fill out a Free Application for Federal Student Aid (FAFSA) via <https://studentaid.gov/> in order for the Office of Financial Aid to receive a notification of a student's FAFSA, the school code for Clinton College must be listed. The school code for Clinton College is 004923.

The FAFSA website is a free U.S. Department of Education website where students may complete and submit a FAFSA application online. A PIN number is necessary for all online applications. All male students are required to register with Selective Service. Registration can be completed and submitted online via www.sss.gov. Continuing students completing the renewal FAFSA can submit an online application via <https://studentaid.gov/>.

How to Apply for Financial Aid: Renewal Application

Renewal of financial aid is not automatic. All applicants must re-apply each year. For additional information on financial aid, you may contact the Office of Financial Aid at (803) 327-7402 ext. 8163. You may also access Clinton College's Financial Aid Manual online via Clinton college website. Students may receive part, or all of the financial aid offered. In such cases, it becomes the financial responsibility of students to provide the balance of aid not accepted.

Types of Financial Aid

Federal Pell Grants

Eligibility for the Federal Pell Grant is determined by a standard formula established by Congress. The formula is used to calculate the expected family contribution. The amount of student aid a student receives depends on the expected family contribution, the estimated cost of education, enrollment status and whether the student attends schools for a full academic year. Pell grant awards are dependent upon program funding.

Federal Supplemental Educational Opportunity Grant (FSEOG)

The FSEOG is for students with exceptional financial need. Priority is given to students who received Federal Pell Grants. An FSEOG does not have to be repaid. Individual awards are based on need and availability of funds.

Federal Work-Study

The Federal Work Study Program provides part-time employment to enrolled students who need earnings for education expenses. The amount of work-study award will depend on the student's financial need and the amount of money allocated for the program. In arranging a job and assigning a work schedule, the Office of Financial Aid considers the need for financial assistance, class schedule, health and academic progress. The student works an assigned number of hours each week, usually in a job related to the student's major or other area of interest. The student is paid current federal minimum wages. The student must obtain a work-study contract from the Office of Financial Aid before reporting to work. The contract will explain in detail the hours the student works, how and when the student will be paid and other terms of the

agreement. In order to continue to be eligible for work-study, his/her work performance must be satisfactory at all times.

The Federal Direct Stafford Loan Program

These are low interest loans that the federal government pays directly to students through their schools. They include Federal Stafford Student Loan, subsidized (need-based) or unsubsidized (with no need). For subsidized loans, the government pays the interest charges; for unsubsidized loans, students are responsible for interest. The interest rate for all loans is recomputed each year. The rate, which is variable, may not exceed 8.25% for student loans and 9% for loans to parents. To qualify for one of these loans, students must be enrolled at least halftime.

Freshmen may borrow up to \$3,500.00 through a subsidized Stafford loan and \$2000.00 through an unsubsidized Stafford loan if they are enrolled in a program of study for a full academic year.

Sophomores may borrow up to \$4,500.00 through a subsidized Stafford loan and \$2000.00 through an unsubsidized Stafford loan if they are enrolled in a program of study for a full academic year.

Juniors and seniors may borrow up to \$5000.00 through a subsidized Stafford loan and \$2000.00 through an unsubsidized Stafford loan if they are enrolled in a full-time program of study for each academic year.

A 1% fee is deducted proportionately from each federal subsidized and unsubsidized loan disbursement. This fee goes to the lending agency to help reduce the cost of the loan. If you do not make your loan payments when they are scheduled, you may be charged collection and late fees. The interest rates for federal Stafford subsidized and unsubsidized loans are set July 1st of each fiscal year by Congress.

After the student graduates, leaves school or falls below half-time enrollment, the student has six months before the student begins repayment. Students receive information about repayment via email or regular mail. Nevertheless, students are responsible for beginning repayment on time, even if they do not receive the information. Under certain circumstances, students may be eligible to receive a deferment or forbearance on their loans.

Scholarships

Additional funding to pay for college may also be received through scholarship awards. Internal scholarship opportunities awarded from Clinton College, for those who qualify, and based on availability of funds, include Athletic scholarships, Band scholarships, Choir scholarships, The Presidential Scholarship and Merit Scholarship. All scholarships have established requirements and guidelines. External scholarship awards are available through various public and private organizations, i.e., UNCF, NAACP, Coca-Cola, and UPS. Students are encouraged to research external scholarship opportunities to determine if they meet the qualifications.

Veterans Benefits

Clinton College follows the guidelines for disbursement of Veteran's Benefits under Title 38: Section 3679(e) of the Veterans Benefits and Transition Act of 2018. This act provides educational assistance for covered individuals under Chapter 31: Veterans Readiness and Employment and Chapter 32: Post-9/11 GI Bill Benefits. (See Policy FA-13: Veterans' Benefits)

Satisfactory Academic Progress Requirements for Financial Aid

Educational institutions are required by federal law to create and implement a Satisfactory Academic Progress (SAP) policy to ascertain student eligibility for Federal Student Aid (FSA). Students must meet BOTH the qualitative and quantitative standards each semester to receive financial aid. (See Policy FA-12: Satisfactory Academic Progress.)

ACADEMIC SERVICES



The Office of Academic Services is designed to support the academic programs of Clinton College through selection, supervision, and evaluation of faculty and professional staff; providing professional development for faculty and staff; budgeting for and providing instructional resources, including library holdings; and improving and maintaining academic programs and assessment systems.

Bachelor's Degree Programs

Bachelor of Arts: Religious Studies
Bachelor of Science: Business Administration
Bachelor of Science: Biology

Associate Degree Programs

Associate of Arts: Early Childhood Development
Associate of Arts: Liberal Arts
Associate of Arts: Religious Studies
Associate of Science: Business Administration
Associate of Science: Natural Sciences

Certificates:

Ministry Studies

The Beacon Academic Success Center

The Beacon Academic Success Center will support the successful retention of students who matriculate at Clinton College. The Staff will focus on providing academic support services to students that will allow them to successfully graduate from Clinton College. The goals of the Academic Success Center are: 1) To encourage students to accept responsibility for their education. 2) To enhance academic performance. 3) To provide retention services that will support students in their academic, cultural, and social development.

Academic Support Services include academic advisement, tutoring in all subject areas, individual support of a learning specialist and academic success coach. All services stated above are free and available to all enrolled students.

Student Support Services. The mission of Student Support Services is to ensure that every eligible Clinton College student that receives Student Support services and participates in the program graduates.

Student Support Services include academic support services and TRIO programs. Student Support Services (SSS) is a Title IV, equal-opportunity program funded by the U.S. Department of Education. The SSS program is a selective program for first generation college students, low income, and/or students with certified disabilities. This program is designed to enhance the overall college experience of our participants and assists them in being successful through supplemental services at no additional cost. Student Support Services at Clinton College are designed to serve as a resource that ensures students are achieving at their best academic level. In addition, SSS serves as a support system as well as an advocate for students.

The Student Support Services (SSS) program will empower our participants academically, socially and culturally by providing a positive atmosphere for learning through tutoring, mentoring, workshops and counseling in all areas of student life. We encourage all qualified students to take advantage of the services offered by the Student Support Service program. The SSS staff is available to help program participants succeed throughout their time at Clinton College and beyond.

Freshman Seminar

Freshman seminar is a class required of all Freshman. The first-year seminar course is designed for first year students, to enhance their academic and social integration into college. Freshman Seminar provides an introduction to the nature of higher education and general orientation to the functions and resources of the college. The course is designed to help first year students adjust to the college, develop a better understanding of the learning process, and acquire essential academic survival skills. The course also provides a support group of students who are experiencing common challenges associated with being a first-year college student.

Digital Library and Learning Commons

The first Library at Clinton College was started in 1894 with a small collection donated by Mr. H. A. Kelsey of Washington, D. C. The present library facility was completed and dedicated in

August 2005. This attractive facility, designed by Harvey Gantt & Associates, has a seating capacity for 48. Special facilities include the Harry B. Dalton Gallery, a multipurpose room, a conference room, a computer classroom, and archive.

In addition to Clinton College Library's traditional print collections, the Library subscribes to electronic databases providing access to resources from JSTOR (Journal Storage), ProQuest's, EBSCO, and a host of other digital database services. Remote access to all electronic resources is available to library users with Internet connectivity. Staff members are available to assist students with finding appropriate research materials for class assignments.

Distance Education

To ensure students that are enrolled in Distance Education courses/programs are successful, the college has clear guidelines and expectations for all academic personnel.

- **Services:** All academic and student support services normally provided in the face-to-face campus environment will be provided to online students through video technology, the LMS platform, the Clinton College website, as well as text, telephone, and email.
- **Faculty and staff credentials:** All faculty and staff providing online academic and student support services must meet the same credentialing requirements as faculty and staff who provide these services face-to-face.
- **Assessment of services:** The annual plans and reports from organizational units that provide online academic and student success services will have the same goals/objectives, benchmarks for success, and assessment methodology as they have for those services when offered face-to-face. The outcomes for distance education services will be compared to outcomes for face-to-face services.

Students' Academic Rights and Responsibilities

Students should check their Clinton College email daily as well as the catalog and the website for information about registration and schedule changes, course offerings and prerequisites, critical dates on the academic calendar, the grading system, withdrawing from courses, and appealing a grade.

Certain information about students' rights and responsibilities is repeated here because of their importance, such as meeting with their advisors, attendance, grade appeal, maintaining satisfactory academic progress, requirements for student athletes, maintaining academic integrity

Advising. All students are responsible for meeting with their academic advisor on a regular basis, completing their academic programs, satisfying the general regulations stated in this catalog, maintaining the required GPA, and meeting all other degree requirements. Students are required to know and observe all regulations concerning campus life and conduct as indicated in this catalog as well as others in the [Clinton College Policy Manual](#) and the [Student Handbook](#). Students are also responsible for maintaining communications with Office of Registration and Records' when changes occur to their current address, including zip code and telephone number.

Attendance. Faculty and the Vice President for Academic Services expect students to attend and participate in their classes on a regular basis in order to derive the greatest benefit from their education. These expectations are described in the Academic Catalog for on-ground, blended, or online classes with synchronous class meetings and for asynchronous online classes that do not have synchronous class meetings. There are negative impacts on course grades for lack of attendance or participation.

What students can expect in terms of attendance and participation is related to the credit hours of a course and whether the course is synchronous or asynchronous (See Policies AS-1: Definition of a Credit Hour and AS-4: Distance Education in the Policy Manual for additional details).

For fifteen week onground or blended/online synchronous courses:

- One fifty (50)-minute lecture period per week for one semester constitutes a semester credit hour in combination with a minimum of two hours of out-of-class work each week.
- A one hundred and fifty (150) minutes lecture period in combination with six hours of out-of-class student work each week for one semester constitutes three semester credit hours.
- Laboratory periods are scheduled 3 hours per week for the equivalent of one credit hour in the four-hour science courses.

For the 7 ½ week asynchronous online courses in Clinton Global:

- Any online courses offered in shorter, more intense time periods must adjust student engagement and off-line independent work accordingly.

Student Grade Appeal. If a student disagrees with a final grade the student must submit a Grade Appeal Request to the Office of Academic Services within 15 calendar days from the beginning of the next semester. The student must submit written documentation to support the appeal with specific reasons they believe the grade is in error. The request for appeal will be sent to the instructor for comments and/or evidence to support or deny the request. The request for appeal must be reviewed by at least two Division Chairs and their recommendation must accompany the appeal. Final approval of the request will be made by the Vice President for Academic Services. All grades are final if there is no pending grade appeal.

Satisfactory Academic Progress. To remain in good standing at Clinton College, all students must maintain satisfactory academic progress each semester in accordance with the Satisfactory Academic Progress policy (See Policy FA-12). A grade point average of 2.0 is required. Failure to maintain satisfactory academic progress may result in probation, suspension, and loss of financial aid.

Requirements for Student Athletes. Student athletes participating in intercollegiate sports must fulfill the Satisfactory Academic Progress requirements to participate in intercollegiate sports.

Academic Integrity. Clinton College expects academic integrity from all students and does not condone academic dishonesty; it expects all students to maintain high ethical standards in all of their coursework. Students found guilty of violating Academic Integrity standards are

subject to a number of penalties. Actions that Clinton College considers violations of Academic Integrity include the following:

- ***Plagiarism.*** Plagiarism is stealing another person's words or ideas and passing them off as your own. When a student puts his or her name on a paper or report or any work assignment at Clinton College, he or she is declaring ownership of the work. The student is saying that he or she has written the work and that the words and ideas contained therein are his or her own, except for the citations from outside sources, which must be documented.
- ***Cheating.*** Cheating includes using materials, resources, or other methods during the course that are not authorized or are not the student's own work. Copying another student's work, whether it is a homework assignment or an examination, is considered cheating. Working together to complete an assignment to be submitted is also cheating, although this does not necessarily apply to group projects assigned by the professor of a course. Sending or arranging for another student to take any graded exercise, quiz, or exam, as a substitute for himself or herself or the student providing information to another student during a graded exercise will be considered a violation of the Academic Dishonesty/Integrity Policy.
- ***Fabrication/Falsification.*** The deliberate creation of non-existent data or results is considered fabrication. Falsification involves changing of data. This also includes students signing attendance rolls for one or more students who are not present.

Course numbering system. Course numbers are related to level of difficulty and expected background of academic experience.

- Courses numbered 100-299: Designed to be taken by freshmen and sophomores but may also be taken by juniors and seniors.
- Courses numbered 300-499: Permitted to be taken only in bachelor's degree programs by juniors and seniors.

Summer Enrollment at Another Institution. Students who wish to enroll at another institution during the summer term must first have approval from the Vice President for Academic Services prior to the end of the spring semester. Courses will not be accepted from other institutions without prior approval of Vice President for Academic Services. Only courses with grades of "C" or better will be accepted as transfer credit.

GRADUATION



Requirements For Graduation

The bachelor's and associate degrees are conferred at the annual commencement upon students who have completed the requirements pertaining to tests, courses, and grades, have paid all college-related charges, and have returned all borrowed books and equipment to Clinton College. Specific requirements for graduation include the following:

- For Bachelor's Degree in: Completion of the minimum of 121 (122 semester hours required for Biology majors without Minor) semester hours required in the major program with a cumulative grade point average of at least 2.00, or as required by a specific major.
- For associate degree: Completion of a minimum of 61 semester hours required in the major program with a cumulative grade point average of at least 2.00, or as required by a specific major.
- A satisfactory score on any required competency and subject area tests.
- A distribution of thirty-one (31) semester hours in general education hours based on specific major requirements.
- Completion of all courses for the major, with a GPA of 2.0 or higher in the major.

Participation in Commencement

Students who have completed all requirements for their degree, and any student(s) within one semester of graduating (lacking no more than 16 credit hours), and who meet all other requirements for their degree, may participate in all commencement activities. These activities include baccalaureate services, commencement, and all celebratory activities. No student will receive a diploma until all requirements for the degree have been fulfilled and all financial obligations have been settled. It is not mandatory for these students with graduating status to participate in the baccalaureate and commencement activities.

Graduation with Honors

Candidates for graduation are eligible for the following honors based upon their cumulative GPAs:

<i>Cum Laude</i>	3.00 cumulative average
<i>Magna Cum Laude</i>	3.33 cumulative average
<i>Summa Cum Laude</i>	3.75 cumulative average

STUDENT SERVICES



Campus Minister

Our campus minister provides a space for students to explore their faith and seek spiritual guidance and support. The campus minister contributes to our student's spiritual and mental well-being through campus worship experiences, forming spiritual groups, life-talk groups, and other supportive events. The campus minister is also available for individual pastoral counseling, and grief counseling

The College Counselor

Our College Counselor offers support to our students through individual and group counseling sessions. In addition to counseling sessions, diverse programming is offered, covering topics of mental health, physical health, the dangers of substance abuse, coping skills and conflict resolution. The Counselor also provides support for our faculty and staff, who can refer students to the Counseling Office.

Career Services

Career Services assist students with identifying and preparing for internships and career opportunities throughout students' matriculation at Clinton College.

Information Technology

The IT Department offers valuable support in tutorials and troubleshooting issues associated with the college issued laptop device, which was provided to our students to meet the demands of

technology associated with today's learning experience. (This department is housed in the Division of Business Services.)

Instructional Technology

The Instructional Technology Coordinator provides support and individualized tutorials to students who may need additional assistance in understanding and navigating Clinton's learning management system. (This position is housed in the Division of Academic Services.)

Student Health Center

Students can receive limited medical services through the on-campus student health center located on the first floor of the Slade Building. The hours of operation for certain services varies. The hours are posted in the Health Center.

DIVISION OF STUDENT SUCCESS



Mission Statement

The mission of the Division of Student Success is to implement effective strategies that provide a safe on-campus environment, offer diverse experiences beyond the classroom, and offer support services that contribute to our students' personal, academic, and professional development, and their overall collegiate experience. The Division of Student Success includes Student Engagement and Retention, Residence Life, Campus Ministry, Counseling, Athletics, and Performing Arts.

Dean of Students

The primary role of the Dean of Students is to educate the entire College community about relevant campus policies and respond to student needs through personal attention and advocacy. The Dean of Students supports students through individual services, innovative programs, co-curricular opportunities and policy oversight and development.

Assistant Dean of Student Engagement and Retention

The Assistant Dean of Student Engagement and Retention manages all aspects of student engagement to include programming, designed to foster student engagement, leadership, and enhance retention. This role also encompasses the responsibility of managing Residence Life.

Residence Life

Residence Life provides a safe, clean, supportive environment, which offers learning experiences beyond the classroom through diverse programming; fosters self-discovery and promotes a sense of belonging within the campus community.

Campus Ministry

Our campus ministry provides a space for students to explore their faith and seek spiritual guidance and support. The campus minister contributes to our student's spiritual and mental well-being through campus worship experiences, forming spiritual groups, life-talk groups, and other supportive events. The campus minister is also available for individual pastoral counseling, and grief counseling.

The College Counselor

Our College Counselor offers support to our students through individual and group counseling sessions. In addition to counseling sessions, diverse programming is offered, covering topics of mental health, physical health, the dangers of substance abuse, coping skills and conflict resolution. The Counselor also provides support for our faculty and staff, who can refer students to the Counseling Office.

Department of Athletics

The Athletic Department provides valuable opportunities through collegiate athletics for students to develop life skills of teamwork, commitment discipline, and work ethic through collegiate competition winning. Student-athletes participating in our collegiate athletic programs must maintain the required GPA and follow all college, team and conference rules, and policies.

Performing Arts

The Department of Performing Arts provides opportunities for our students to expand their learning experience beyond the classroom through activities, involving music, theater, dance, choir, spoken word, Beacon Forum or Worship Service.

STUDENT ENGAGEMENT



Student Engagement

The Department of Student Engagement is an integral part of contributing to our students overall collegiate experience. By providing diverse activities, programs, and organizations both on and off campus, students are able to have diverse learning experiences beyond the classroom and become active members of the Clinton College campus community. Participation in various activities also provides opportunities for students to showcase existing skills or, develop new skills and interests through new activities. Students are strongly encouraged to take advantage of the opportunities to enhance their collegiate experience by attending events and supporting fellow students or participating in events.

Currently students have the opportunity to participate in athletics, campus organizations, community organizations, choir, cheerleading, drumline, and SGA. The Department of Student Engagement welcomes suggestions from all students to offer activities, programs and organizations that reflect the interest of the student body.

Student Government Association (SGA)

The Student Government Association provides an opportunity for student participation and leadership, and early experience in self-government. The purpose of the Student Government Association at Clinton College is to:

- Express student concerns
- Safeguard student interests
- Facilitate effective communication between administration, faculty, staff, and students
- Sponsor events for the general student population
- Enhance student life on campus

- Acknowledge and support student clubs and organizations by sponsoring events for the enrichment and enhancement of the student body
- Encourage participation in all aspects of student life

The Student Government Association consists of two divisions:

- ***Executive Council*** is composed of President, Vice President, Secretary, Treasurer, Parliamentarian, and Chaplin.
- ***Student Senate*** is composed of five to ten full-time students that are nonvoting members who attend SGA meetings and SGA sponsored programs.

Student Organizations

Students have the opportunity to join existing clubs/ organizations or with the guidance of the Office of Student Engagement, start a new club or organization. Current organizations include:

- Cheerleading/dance
- Drumline
- Choir
- Rotaract Club
- NAACP
- SGA
- Performing Arts

Athletics

Opportunities to participate in collegiate athletics includes men's and women's basketball, cheerleading, drumline, team manager or game day staff. It is the policy of Clinton College that any student interested in becoming a member of the college's collegiate athletic teams, must have graduated from high school or had received a General Education Diploma (GED) before the season officially begins, and maintain the established GPA of the college and governing conference to be eligible for competition. Students are allowed to participate in collegiate athletics for a maximum of four academic years per each sport.

Try Outs

Try outs are conducted at the discretion of the Head Coach or Athletic Director. Students that make the team may be offered an athletic scholarship or be a non-scholarship student-athlete.

Athletic Scholarships

Clinton College athletic scholarships cover the cost of tuition and are awarded at the discretion of the Head Coach or Athletic Director. Athletic scholarships are awarded to potential student-athletes that the coaching staff recruits from various states throughout the country. The student athlete must be on course to graduate from high school or be making progress to receive their G.E.D. If these qualifications are not met before the beginning of school the scholarship shall be voided. Scholarship athletes as well as non-scholarship athletes must pass a minimum of 12 credit hours per semester with at least a 2.0 grade point average in order to keep their scholarship and remain on the team. At the conclusion of one year in attendance, the student athlete must have earned a minimum of 24 credit hours with a cumulative GPA of 2.0 or better in order to be eligible for participation the following year.

Code of conduct (student-athletes)

Clinton College student-athletes must abide by all Clinton College rules and regulations as established in the student handbook and Clinton college the governing athletic conference, and team rules as established by the Head Coach.

Spiritual Development Opportunities

The affiliation of Clinton College with the AME Zion Church and its accreditation by TRACS means that Clinton College has a responsibility to provide faculty, staff, and students opportunities for spiritual development. All faculty, staff and students are encouraged to take advantage of opportunities for spiritual growth, through the scripture readings, prayers, and content of the Fall convocation, baccalaureate, graduation ceremony, as well as Beacon Forum programs and worship services by the campus minister.

The mission of Beacon Forum programs is to provide stimulating programming that encourage students to:

- explore, discover, and deepen their spirituality
- develop an appreciation of spiritual diversity with a view to mutual enrichment
- integrate the spiritual and intellectual dimensions of life
- engage in ethical reflection and the discussion and development of values, and construct a vision of what they can contribute to the common good

All students must be properly dressed for Beacon forum: All faculty staff and students are given Clinton College Blazers to be worn at Beacon Forum and other special campus events. In addition to the Blazer, dress or pants, slacks, shirt, and dress shoes are required.

Opportunity for Community Outreach

The Department of Student Engagement coordinates opportunities for faculty, staff, and students to participate in community outreach through participation in local and national organizations i.e., Rotoract club, NAACP, and Habitat for Humanity. Previous activities have included food drives, feeding the less fortunate for the holidays, building sleeping mats for the homeless, and other opportunities that reflect the interest of our students, and contribute to the advancement of our local community.

RESIDENCE LIFE



Residence Halls

There are two residence halls on the campus of Clinton College:

- **Cauthen Hall** is a two-story, single gender (*female*), double occupancy residence hall. It has the capacity for 70 students. All rooms have the following amenities and furniture: 1 closet, 2 desks, 2 chairs, 2 XL twin beds, 1 micro-fridge, internet connection (Wi-Fi), and cable TV outlet. The living accommodations for the Area Coordinator is a first-floor efficiency apartment with a connecting office. Cauthen Hall is located on campus near the cafeteria.
- **Marshall Hall** is a two-story, single gender (*male*) double occupancy residence hall. It has the capacity for 76 students. All rooms have the following amenities and furniture: 1 closet, 2 desks, 2 chairs, 2 XL twin beds, 1 micro-fridge, internet connection (Wi-Fi), and cable TV outlet. The living accommodations for the Area Coordinator is a first-floor efficiency apartment with a connecting office. Marshall Hall is located directly across the street from the campus.

Mission of Residence Life

Residence Life provides a safe, clean, supportive environment, which offers learning experiences beyond the classroom through diverse programming; fosters self-discovery and promotes a sense of belonging within the campus community.

Residence Life Diversity Statement

Residence Life values the diversity of students on our campus. We embrace everyone who makes up our community while providing opportunities for education and support in an increasingly global society.

Safety and Security

The safety and security of our residential community is a priority for our Residence Life Administration. Each residential hall has an Area-Coordinator, Resident Assistant and Campus Security Officer which provides security and leadership within each dorm. In addition, policies, procedures, and programs regarding safety and security, are discussed with residents. Additional details regarding safety are also included in this publication.

Residency Requirements

Clinton College is a residential community; therefore, freshman and sophomore students are required to live in on-campus housing for two continuous semesters. The age limit for residing in the halls is 25 years old. (See Policy SS-6: Residence Hall Policies in the Policy section of this handbook and in the Policy Manual)

Residence Life Administration

The Residence Life Administration is comprised of the following staff:

- Assistant Dean of Engagement and Retention – Manager of Residence Life
- Area Coordinator – Lead supervisor in each residential hall
- Resident Assistants – (RA) students selected by the Area Coordinators to assist in the duties related to operations within the residential halls.

In addition to providing guidance, support and information, the staff is responsible for monitoring student conduct, planning programs and offering peer counseling. Any reasonable requests made by student RA's should be respected just as those of any other Clinton College Official.

Applications

Applications for campus housing must be submitted for each year in which housing is desired. The application process will vary according to a student's classification as a new or continuing student. Re-admission status is considered the same as new student status.

Continuing students are required to complete a housing application each year. Usually, this application period will coincide with the class pre-registration period held each semester. An application for campus housing does not necessarily ensure an assignment to housing.

To be eligible to apply for housing, students must:

- 1) Meet all academic requirements for entrance to or continuation in college.
- 2) Be pre-registered as a full-time student for the semester in which the reservation is made.
The requirement for pre-registration does not apply to new students. Reservations will not be held past the first day of the start of classes on the first day of the semester.

Applications accepted during pre-registration periods will be cancelled at the end of the semester in which the reservation is made if, at the end of that semester, the student is declared academically ineligible.

Room Reservation Fee

There is a \$150 non-refundable reservation fee room fee that must be paid at the beginning of each semester for residential students. The student may be charged additional fees for any damage found in the room at cost. Examples include replacing keys, doors, damaged to furniture mattresses and covers and replacement of blinds.

Abandoned Property

Students' personal property that is left in a vacated room, hallway, lobby, or common space, will be disposed of within 24 hours. The student's account will be billed appropriately for the labor involved as well as for improper checkout and possible key/core replacement.

Appliances

Students are permitted to have microwaves and refrigerators in their rooms, and the College provides one micro-fridge combination per room. However, the following restrictions apply if students desire additional appliances:

- 1) Refrigerator – Two refrigerators, which are 4.5 cubic feet or less will be permitted per room.
- 2) Students must bring their own refrigerators. The College will not permit companies, organizations, or individuals to rent refrigerators to students.
- 3) Microwave wattage – 1200 watts or less. Size – 1.6 cubic feet or less.
- 4) If problems occur as a result of the possession of a refrigerator or microwave, a student may be asked to remove it from the residence hall.
- 5) Two microwaves are allowed in each room.
- 6) Only computers, alarm clocks, TVs, stereos, hair dryers, fans, razors, or lamps may be attached to an electrical outlet without permission from the Office of Residence Life.
- 1) Sunlamps and cooking utensils with open coils WILL NOT be approved. The College may ask the student to remove any appliance if problems arise from its use.
- 7) Extension cords are not permitted as means of providing electricity to in-room appliances. All students should use UL-listed power strips and/or stations when additional electrical outlets are required. Rock Hill Fire Department recommends power strip/stations with on/off switches and surge protectors.
- 8) Although the heat and air conditioning in the Residence Halls are serviced regularly, students may request supplemental heating sources. Outside space heaters purchased by the student are not permitted in the Residence Halls.

Open Flames / Burners / Halogen Lamps

Candles, incense, cigarettes, electronic cigarettes, hover boards, halogen lamps, space heaters, and any appliance with an open burner are fire hazards and are not permitted in the residence halls on the campus of Clinton College. If found, the item(s) will be confiscated, and a fee will be assessed and billed to the student's account.

Floor/Hall Meetings

Residence Life staff may call a Dorm or floor meeting to discuss various policies and information. All residents are held accountable for the information and are, therefore, expected to attend all floor and/or hall meetings.

Quiet Hours

The residence halls are both living and learning environments. Common courtesy hours are practiced 24 hours a day, especially in all common areas. Students living in the residence halls must be considerate of their fellow community members. Area Coordinators will determine any additional specific study or quiet hours for their building.

Work Order Repairs and Process

Residents should notify the RA, Area Director, or the Office of Residence Life if problems occur and/or repairs are needed in their rooms. Notify the RA if the problem is in a common area. In case of an emergency, and the RA cannot be located, call the Office of Residence Life (ext.8153) or Assistant Director of Residence Life (ext. 8183). During normal work hours (8:30 a.m. – 4:30 p.m., Monday through Friday), the Office of Residence Life must approve any work order prior to being submitted to the Director of Facilities. At night and on weekends, Physical Plant personnel may be contacted only through the Residence Life Professional on duty. Please contact your RA on duty first to access these individuals.

Stolen or lost items in the Residence Halls

The College is not responsible for the loss of, damage to, or theft of students' items anywhere in the residential halls. It will be the student's responsibility for losses, and they are advised to contact family to see if home owner's insurance policies provide coverage for losses. Any incidents should be reported to the Residential Life Coordinator, Campus Security, and/or the Rock Hill Police Department.

Storage

All student property must be stored in the student's room. Clinton College will not store excess personal property. Additionally, Clinton College will not store students' personal belongings over the summer break.

Withdrawal from the Residence Hall

At the time of withdrawal from the dormitories, students must have their rooms inspected by the residential hall staff. Students that fail to complete the withdrawal process will continue to be charged for room and board and will forfeit their room deposit.

Housing During Breaks/Holidays

Room and Board fees do not include student vacation periods. Students will not be allowed to stay on campus during summer. During the academic year, students will be notified of periods in which they can stay on campus if the residence hall is open and the dining hall is available. Residence Halls will be closed within 24 hours of the last exam and by 6:00 p.m. of last day of classes. Opening and closing of the residential halls will be posted and listed on the Academic Calendar.

Students' Right to Privacy in Residence Life

Room Inspection

Clinton College respects a student's right to privacy in his or her residence hall room. Accordingly, College officials will enter rooms only to inspect for reasonable cleanliness and order, standard maintenance, preservation of existing structure, identification of damage, complete maintenance orders, or to enforce College rules, for protecting the safety and security of members of the College community and their property. Inspections do not involve searches for rule violations. However, under the "plain view" rule, when inspections by College staff reveal evidence of rule violation, students will receive notification and any evidence removed from the room.

Room Searches

Room searches to enforce College rules follow the procedures to protect the privacy rights of students. Searches will be conducted by college officials, based on probable cause that a rule violation has been committed, and that the evidence for it may be found in a particular room. The search may proceed only after the probable cause, the place to be searched, and the things to be seized have been described to the Dean of Students and have granted permission to conduct the search. Whenever practical, the search will be conducted in the presence of the resident(s) of the room. The College reserves the right to remove illegal items or unauthorized College property that is found during authorized searches.

Standards of Conduct in the Residence Halls

Below is partial list of Residential Hall rules, regulations, and policies. All policies, rules and regulations for students residing on-campus are included in the Residential Hall leasing agreement and covered by residential hall staff in residential hall meetings. When deemed necessary Clinton College and or the Residence Life Administration have the right to amend the rules, regulations, and policies without advance notice to students. Amendments made will immediately be provided to all residential students. A residential student's failure to comply with all residential hall policies, rules and regulations, could result in warnings, sanctions, judiciary hearings, suspension, expulsion or loss of on-campus housing.

- *Solicitation / Fundraising.* Individuals soliciting or fundraising for business, volunteers, or religion within the residence halls is not allowed. Students should report individuals immediately to a staff member. Permission for soliciting/fundraising must be approved by the Vice President for Enrollment and Student Success.
- *Smoking.* Smoking is prohibited in the residence halls' common areas and/or student rooms and on college property.
- *Theft.* Students are not allowed to take/use cell phones, clothes, credit cards, or other items that belong to their roommates or hall mates. Individuals who do so are subject to the College Conduct Process and may be subject to face criminal prosecution.
- *Weapons.* Weapons are not allowed in the residence halls of Clinton College. Weapons include knives, pocket-knives, guns, pellet-guns, projectile weapons, tasers and martial arts equipment (num-chucks, Chinese stars, etc.). Additionally, common utensils must not be used as weapons.

- *Harassment / Sexual Harassment/ Fighting/ Bullying.* Harassment of any type is not tolerated in the residence halls. Physical, verbal, sexual and/or electronic harassment will be handled through a conduct hearing. Members of the Clinton community who experience any type of abuse or harassment should contact their RA to report the information. (Reference the Clinton College Title IX, Sexual Violence, Sexual Harassment, Sexual Assault Policy)
- *Illegal Use of Drugs and Drug Paraphernalia.* Illegal use of drugs, illegal drugs, and drug paraphernalia are not allowed in the residence halls or on the Clinton College campus. If, after a conduct hearing, a student is found responsible for the use or possession of illegal drugs, the resulting sanction will include written notification of policy violation; additional sanctions could include community service; temporary or indefinite suspension or dismissal from the residence halls; or the temporary or indefinite suspension or dismissal from the College.
- *Intoxicated / Incapacitated Students.* Students who appear intoxicated through slurred speech, inability to focus, physically unbalanced, unusual behavior, and/or smell of alcohol may be confronted by a campus security officer, or Clinton College employee. If this should occur, the student should comply with Clinton College officials. If a student is obviously intoxicated/incapacitated and is vomiting or to the point of passing out, Clinton College officials will call for an ambulance, at the expense of the student, to ensure the student's safety.

Renter's Insurance for Students' Items

The College is not responsible for items in the students' rooms. Although the college does not require it, it's encouraged for students to obtain renter's insurance if parents don't have homeowner insurance to cover their student's items while in college. Items left over 10 days will be disposed of by college staff. Students should record their items serial numbers on the form given by the Residence Life Staff in case an item is stolen for recovery purposes.

Student Health Center

Students may receive limited medical services through the on-campus student health center located in the Slade bldg. on the first floor. The hours vary for services. The hours are posted in the Health Center.

Student Health Insurance

Any full-time student must have health insurance and show evidence of insurance during their enrollment.

Medical Emergencies/Other Emergencies

Clinton College is not equipped with an infirmary on campus. In the event of a medical emergency on campus, contact Campus Security or in the residence hall, contact the Area Director.

In the event of a break-in, violent attack, car, or other accident/emergency, call 911 to contact the Rock Hill Police Department, and also contact Campus Security, Residence Life Staff and/or administrative offices.

Severe Weather Procedures

In cases of severe weather, the Office of Residence Life will notify residents in person and/or through signs on the entrances of the residence halls. The information will give the specific procedures to follow. For the safety of all residents, please follow these procedures as stated and do so as quickly, calmly, and quietly as possible. As in a fire drill, all students in the residence halls are expected to cooperate fully. Should Rock Hill encounter severe weather, such as an ice storm/snowstorm, call the College will give for the latest information concerning any delay or cancellation of classes via email, text and on the college website.

Fire Drill and Evacuation Procedures Regulations:

Required: These rules must be strictly observed at the sound of the alarm.

- 1) Wear coat and shoes.
- 2) Turn on light(s).
- 3) Lower or close windows and open the shades/blinds.
- 4) Leave room; close all doors.
- 5) If on a floor other than your own, borrow the articles of clothing and leave the building with the group on that floor and join your own group at their appointed station.
- 6) Walk quickly and quietly to your designated station. Remain silent so roll call can be done.
- 7) Remain in a group until RAs give the "all clear."
- 8) Proceed quietly into the building and return to your room.

Recommended: Upon check-in to the residence hall, you should:

- 1) Locate the exit closest to your floor and find an alternate exit.
- 2) Keep your room key within easy access at night.
- 3) Read the fire evacuation route located on each floor.

In case of fire, remember:

- 1) Crawl instead of walking upright.
- 2) Check to see if doors are cool before opening.
- 3) Do not use the elevators.

If trapped in your room:

- 1) Call the Fire Department at 911 and let them know the location.
- 2) Seal off door and window cracks to keep smoke out. If possible, wet walls and furnishings.
- 3) Tie a wet towel around your nose and mouth.

Fire Safety Guidelines and Regulations

DO —

- 1) All students should use UL-listed power strips and/or stations when additional electrical outlets are required. Rock Hill Fire Department recommends power strips/stations with on/off switches and surge protectors.
- 2) Use only metal wastebaskets.
- 3) Keep fire doors in corridors and stairwells closed at all times.
- 4) Keep furniture, tapestries, or wall hangings away from doorways.
- 5) Keep less than 20% of the total wall area covered with combustible materials.
- 6) Report any safety or fire hazards to the Office of Residence Life staff immediately.
- 7) Keep hallways, breezeways, and walkways clear of personal items

DON'T —

- 1) Bring gasoline or any other volatile liquids into the residence halls.
- 2) Overload outlets.
- 3) Suspend items from the ceilings, sprinkler system or cover air/heat vents with plastic trash bags or suspend air fresheners.
- 4) Use extension cords.
- 5) Leave permitted appliances unattended while on and/or plugged in.
- 6) Use an open coil appliance (such as toaster, toaster oven, etc.).
- 7) Keep personal belongings in hallways, breezeways, and walkways. Students found guilty of pulling fire alarms, tampering with smoke detectors, removing evacuation procedures, and misusing the fire extinguisher(s)/fire hose(s) will be held accountable through a conduct hearing, fined the appropriate fees, and may face federal charges.

STUDENT CODE OF CONDUCT



Student Code of Conduct

The Student Code of Conduct exists to protect the members and property of Clinton College, and enhance the educational experience, and overall mission of the college. It is the responsibility and the duty of every student to have knowledge of the Student Code of Conduct and to agree to abide by the Student Code of Conduct as a condition of enrollment. Ignorance of the Code of Conduct and its provisions will not constitute a defense in any proceeding against a student. The Student Code of Conduct outlines the rules, regulations, sanctions, and judiciary process for student conduct, while matriculating at Clinton College. (See Policy SS-3: Student Code of Conduct in the Clinton College Policy Manual.)

Students are expected to abide by all Clinton College policies, rules, regulations, standards and by laws of the City of Rock Hill, York County, State of South Carolina, and the Federal Government. Therefore, legal action in addition to college disciplinary action may occur. The College's decision in disciplinary matters is independent of off-campus legal action, except that any student convicted of criminal misconduct, whether occurring on campus or not, may be suspended or expelled from the College.

While the Student Code of Conduct does not include all the actions, or violations that may adversely affect the community, they do apply to the conduct of all students and student organizations while on college owned or controlled property and off the campus, as long as, the student or student organization maintains a student relationship with the College. College owned or controlled property include all lands, buildings, and facilities owned, leased, or operated by the College. The College reserves the right to sanction currently enrolled students for violations of the Student Code of Conduct, even if said violations occur off campus. In accordance with the

College policy, disciplinary action under these guidelines may be taken against an individual who has matriculated at the College, even though the student may not be currently registered for classes (e.g., during semester breaks and during the summer).

Persons are encouraged to promptly report violations of the Student Code of Conduct to a College employee, Campus Police, Residence Life personnel, or the Dean of Students Office. The College decision in disciplinary matters is independent of off-campus legal action, except that any student convicted of criminal misconduct, whether occurring on campus or not, may be suspended from the College.

A student does not begin each semester, term, or school with a clean record. Other more severe sanctions may be imposed when deemed appropriate and necessary. Students' prior offenses are cumulative and may subject the student to more severe penalties for subsequent offenses.

In its attempt to promote and ensure fairness and consistency in disciplinary decision making, the College has suggested specific sanctions for violations of the Student Code of Conduct. Adjudicators should consider the following suggested sanctions. Students found responsible for infractions will receive, as a minimum, the sanctions indicated. The College reserves the right to apply a different sanction/stipulation for a violation of the Student Code of Conduct depending on the nature and gravity of the violation. In cases when students' misconduct is inextricably mixed with academic issues, the process outlined in this policy will be followed. This does not preclude academic sanctions separate from this process.

If it is determined that a student has possession of, use, or distribution (trafficking) of drugs; or using any object with the intent to cause harm, to him/herself or others, the sanctions may include

- Suspension from the College for one (1) academic semester, or possible expulsion from the College. Suspension from the College will result in the cancellation of the responsible student's housing contract and possible denial of a housing contract in the future.
- Expulsion is permanent dismissal from the College with no opportunity for re-admission.

Because the conduct system is designed to help correct behavior and to fulfill an educational purpose, it is expected that any student who must go through the conduct process will, as a result, be duly warned about his or her behavior, encouraged to comply with the Student Code of Conduct, and notified about possible sanctions if subsequent violations should occur. Moreover, the system of consequences must be imposed to maintain order and to protect the rights and privileges of others in the College community. Therefore, students who are found responsible of the same offense more than once or of a second offense of equal or greater magnitude, (as defined by the nature of the sanction) may be suspended or expelled from the College.

Authority for Imposing Student Sanctions

The Vice President for Academic Services or designee is responsible for discipline in the academic setting (classroom), and the Vice President for Student Success/ Dean of Students or designee is responsible for discipline in all other aspects of campus life.

There are times the Vice President for Academic Services and the Vice President of Student Success / Dean Students will forward disciplinary cases to the college's Judicial Board.

Cases that are referred to the Judicial Board are referred at the discretion of the Vice President for Academic Services and the Vice President of Student Success/ Dean of Students. This board serves as an advisory board to the Vice President for Academic Services and the Vice President of Student Success/Dean of Students. Once a disciplinary case has been forwarded to the Judicial Board, there is an appeal process. All appeals should be forwarded to the Judicial Appeals Officer in writing.

Disciplinary Sanctions

Sanctions are imposed to protect the College community from behaviors that are detrimental to the educational process and/or the College community members. Sanctions and stipulations within the Student Code of Conduct are designed to emphasize appropriate conduct within the College community and within our global society.

Students are also advised that a disciplinary sanction(s) imposed by the College does not preclude the possibility that a separate criminal or civil prosecution may follow, and that questionable conduct in the non-College community may be grounds for college disciplinary action as well. Students placed on probation, suspension from the College, or suspension from the residence halls are expected to demonstrate a positive change in their behavior. During the sanction period, the student may be denied participation in campus activities, both on and off campus. Such students may not represent the College in any public function or performance, hold office in a student organization, or be eligible to join campus organizations, while they are completing probation or suspension.

All sanctions imposed by the College and Office of the Dean of Students, or V.P. of Academics are effective immediately and will not be postponed to accommodate exams, graduation, or other schedules. Failure to comply with outlined conduct sanctions may result in immediate sanctions including suspension with or without the advantages of a conduct hearing.

Violations

The College reserves the right to impose sanctions that it deems an appropriate response to student misconduct. The following violations are only examples of misconduct and are not an all-inclusive list of violations. **SANCTIONS AND STIPULATIONS MAY BE IMPOSED FOR CONDUCT NOT DESCRIBED BELOW.**

- *Drugs.* Clinton College complies with federal, state, and local laws including those which regulate the possession, use, and sale of narcotics, illegal drugs, or controlled substances. Clinton College prohibits the unlawful manufacture, distribution, dispensation, presence or use of illegal drugs, or other controlled substance on its property or at any of its activities. The manufacture, use, possession, sale, purchase, or transfer of illegal drugs by a student is prohibited, and will result in written notification of violation, and or community service, loss of campus housing, suspension, or termination of enrollment.

- *Alcoholic Beverages.* Clinton College complies with federal, state, and local laws including those which regulate the possession, use and sale of alcoholic beverages. The possession of alcoholic beverages either opened or unopened container, anywhere on college property, including cars and other vehicles is prohibited. This also includes drinking alcoholic beverages in residential halls, classrooms, administrative building, campus lawn, dining room, and at campus activities. This is also inclusive of possessing empty alcohol cans and/or bottles. The use, possession, sale, purchase, or transfer of alcoholic beverages will result in written a notification of violation, and or community service, possible loss of campus housing, suspension, or termination of enrollment.

- *Drug and Alcohol Abuse.* The purpose of the Clinton College Drug and Alcohol Prevention Program (DAAPP) is to encourage responsible behavior; regulate the use of alcohol and controlled substances on Clinton College property; support state and local laws; provide a program of intervention, education, and support; and establish appropriate judicial sanctions/employment decisions for those who violate the policy. The DAAPP policy (HS-7) is located in the Critical Policies section of this handbook, in the Policy Manual and on the Clinton College home webpage. It is also emailed to all current, faculty staff and students.

- *Tobacco Free Campus.* As an institution of higher education, Clinton College recognizes its responsibility to provide education our students on matters of good health. The use of tobacco products is a privilege, not a right which, when abused or excessively practiced in the presence of both tobacco users and non-tobacco users, can be offensive and harmful to health.
 - Smoking is prohibited in all buildings and all grounds of Clinton College.
 - Smoking or other use of tobacco is not allowed inside any Clinton College facility.
 - Smoking or the use of any tobacco products is not permitted on the campus of Clinton College.

- *Theft.* Theft, regardless of where it occurred, stealing from another person, agency, institution, or the college; the taking of property belonging to another, with the intent of converting the property to one's personal use is prohibited, and the College will take necessary disciplinary action against all persons proven guilty of theft.

- *Damage, Defacing, Abuse, or Destruction of College Property.* Damage, defacing, abuse, or destruction of college property is a violation of the Student Code and prohibited and violators are subject to sanctions.

- *False Information/Misrepresentation*
 - a) Knowingly furnishing false information to the College or its officials, or other forms of dishonesty in college-related affairs, including making a false statement to any member of the College community with the intent of deceiving, including perjury is prohibited and subject to sanctions.

- b) Misrepresentation, forgery, alteration, destruction, misuse, or attempted or intended misuse of college documents, records (including altering work time sheet), identification, or other property, and the unauthorized transfer, sale, and use of computer applications are prohibited and subject to sanctions.
 - c) Fraud -This encompasses fraudulently obtaining, fabricating, altering, falsifying, transferring, loaning, selling, misusing, or attempting to misuse an ID card, meal card, enrollment validation sticker, library card, vehicle registration, or other College document or service; transferring, lending, or selling such items; giving false name, date of birth, Social Security number, or other identification to a College official; or otherwise engaging in fraudulent or deceptive acts with the intent to defraud or deceive is prohibited and is subject to sanctions.
- *Disorderly Conduct.* Disorderly conduct means any offensive or annoying act that disrupts the peace. It includes, but is not limited to, conduct that is offensive or disrupts the rights of others. It includes excessive noise, such as loud talk or shouting in such a way that violates the right of others to live in an atmosphere conducive to learning and study. The scope of these activities includes College-owned or controlled property and College sponsored or supervised activities. Students are responsible for the behavior of their guests and students may receive sanctions if they permit their guests to indulge in disorderly conduct on campus.
 - a) Disruptive classroom behavior - this includes any disruptive behavior within the classroom or instructional setting.
 - b) Moral or decency offenses - this is defined as lewd, indecent, or obscene conduct or expression or other moral decency offenses.
 - *Failure to Comply*
 - a) Failure to comply with the direction of college officials and Student Employees acting in the performance of their duties, or refusal to present proper identification upon the request of a College official.
 - b) The willful failure of a student to allow College officials entry to his or her motor vehicle (as owner, operator, or registrant), residence hall room, or any other facility on campus upon grounds of reasonable suspicion.
 - c) Failure to comply with student conduct, sanctions will be unilaterally imposed without a college hearing by the Office of Dean of Students.
 - *Physical Abuse.* This is defined as an encounter in which physical contact occurs between two or more persons, an encounter with blows or other personal violence, which includes rape, sexual assault, pushing, shoving, and other acts of physical abuse, between two or more persons, or conduct which threatens or endangers the health or safety of another, including assault and battery on or off the campus. If weapons or objects that are used as weapons or which may be constructed as weapons are used in an altercation, the student may be automatically suspended from the College. Any student(s) alleged to have violated this policy may be immediately suspended or expelled from the College.

- *Rape or other sexual assault* - Any student(s) alleged to have violated this policy may be immediately suspended or expelled from the College on a temporary basis, pending the outcome of a Student Conduct hearing. (See Policy GA-6: Title IX – Sexual Harassment Grievance in its stand-alone section in this handbook and in the Policy Manual.)
- *Verbal Abuse, Defamation, or Harassment.* This violation is defined as the use of verbally abusive language by any person on college owned or controlled property or at college -sponsored or supervised events. This includes language that degrades, insults, taunts, or challenges another person by any means of communication, verbal or nonverbal, to provoke a violent response, communication of a threat, defamation of character, use of profanity, verbal assaults, derogatory, sexist, or racist remarks or any behavior that puts another member of the College community in a state of fear or anxiety.
- *Hazing.* The college does not condone any hazing or mistreatment of another student so as to cause mental or bodily injury. The Dean of Students and Vice President for Enrollment Management and Student Success shall, upon satisfactory proof of violation of this policy by any student, expel the guilty party and, if appropriate, report the incident to local authorities for criminal prosecution.
- *Weapons.* The possession of firearms, ammunition, explosives, incendiary devices, or other weapons on the Clinton College Campus is prohibited. A “weapon” shall include anything likely to be used, or designed to be used, in destroying, defeating, or injuring a person or property damage; or an instrument by the use of which a fatal wound may include, but is not limited to, the following: any firearms, BB gun, pellet gun, ammunition, bow and arrow, cross-bow, slingshot, cross knuckles, knuckles of lead, brass or other metal, any bowie knife, dirk, dagger, or similar knife, or any knife having the appearance of a pocket knife, the blade of which can be opened by a flick of a button, pressure on the handle or other mechanical contrivance. (See Policy HS-4: Weapons)

Types of Sanctions for Violations

The following disciplinary sanctions, singularly or in combination, may be imposed on a student found responsible for violation of the Student Code of Conduct. THE LIST OF SANCTIONS AND VIOLATIONS LISTED BELOW IS NOT INCLUSIVE OF ALL VIOLATIONS and OR COMBINATIONS OF SANCTIONS. Sanctions will be determined based on the violation and any other significant factors. Sanctions may be issued by the College President, V.P. Student Success/ Dean of Students, Judiciary Committee, V.P. of Academic Services, Asst. Dean of Student Engagement/Retention, or designee. The College administers 5 official sanctions for violations and or infractions of the Student Code of Conduct.

Type of Sanction I: Warning

- ***Verbal Warning*** -A verbal disciplinary warning is provided on the scene, at the moment of a minor, non-violent or threatening violation. The student is also warned that a repeat of the same violation will result in a written warning and or additional sanctions.

- **Written Warning-** A disciplinary warning or reprimand is an official statement of censure, warning the student of unacceptable conduct in an incident considered to be one of minor consequences. The official warning or reprimand is a written notification issued to the student that he or she has been found in violation of the Student Code of Conduct and that any other violation for which the student is found responsible will result in more severe disciplinary action. In addition, the warning or reprimand will become a matter of record in the Dean of Students Office.

For Minor, Non-violent, and Non-threatening Acts (not an all-inclusive list of violations):

- a) Loud or disruptive music beyond established study hours, or during college event.
- b) Loud or disruptive non-violent, non-threatening speech or behavior.
- c) Unauthorized assembly which interferes with the normal operation of the College.
- d) Having unauthorized guest in the Residence Hall.
- e) Having pets in the Residence Hall.
- f) Violating Dress Code.

Type of Sanction II: Community Service

Based on the violation, when appropriate, students may be assigned volunteer community work to be completed at the college or in the local community. In some cases, community service will be an alternative to, or in conjunction with other sanctions. This will not be used to degrade the individual or hinder his or her academic progress. Off-campus assignments are usually made in conjunction with volunteer service agencies. All assignments must be completed within the period designated and to the satisfaction of the assigned supervisor. Students who fail to complete their assignments in a satisfactory manner will be considered in violation and will be subject to additional disciplinary action, including suspension or expulsion from the College.

For the following violations (not an all-inclusive list)

- a) Repeat offender - Student who has already received verbal and written warning for previous violation(s). (Not an all-exclusive list of violations).
- b) Misconduct and inappropriate behavior.
- c) Unruly and or threatening behavior.
- d) Failure to respond appropriately to a College Official.
- e) Theft.
- f) Use or possession of illegal drugs or drug paraphernalia.

Type of Sanction III: Probation

Students placed on probation are expected to demonstrate a positive change in their behavior. During the probation period, the student shall be denied participation in intramural, intercollegiate, and club sports. Such students may not represent the College in any public function or performance, hold office in a student organization, or be eligible to join any campus organizations, during their probationary status. In addition, the sanction of probation will become a matter of record in the Office of Dean of Students. Students who have been placed on disciplinary probation twice in the same academic year may receive more severe sanctions, such as suspension from the College.

For the following violation(s): (Not an all-inclusive list of violations)

- a) Student has violated the conditions of his/her disciplinary probation.
- b) Student has committed a violation considered to be severe in nature and scope.

Type of Sanction IV: Suspension

A student found guilty of violating his/her probation, or who commits an offense serious enough to warrant suspension, may be suspended from the College for the remainder of that semester, and/or for an additional period. Usually, the designated period of suspension will not exceed one year. Suspensions are noted in the student's permanent record. Students suspended from the College may not return to the campus for the duration of their suspension, except to conduct official business with the administrative officers or faculty members, and then only with the permission of the Vice President of Student Success/ Dean of Students.

For the following violation(s): (Not an all-inclusive list of violations)

- a) Physical abuse/fighting/hazing.
- b) Theft.
- c) Possession with the intent to distribute Illegal drugs.
- d) Illegal use of drugs or alcohol.
- e) Possession of firearms and weapons.
- f) Threats/Harm to faculty/staff/student(s).

Type of Sanction V: Expulsion

Expulsion is the most severe sanction that can be imposed upon a student for violation of the Student Code of Conduct. Expulsion is permanent dismissal from the College, and the student's relationship with the College is permanently severed. The student is not only subject to the conditions and restrictions cited under suspension but is also not eligible to apply for re-admission to the College. Students expelled from the College are required to return their student identification card, room keys, and laptop device and may not return to the campus. If an expelled student returns to campus without permission, the student may be subject to criminal charges, including but not limited to, trespassing.

If a student is expelled from the College, notification may be sent to his or her parents or guardians notifying them of the expulsion. Expulsions are recorded on the student's permanent record. Any student(s) alleged to have violated, at minimum, any of the following Student Code of Conduct will be immediately suspended on a temporary basis, pending the outcome of a Student Conduct Hearing. If the student(s) is subsequently found responsible for the violation, the student(s) will be subject to long-term suspension and/or expulsion from the College.

In the case of serious violations of the Student Code of Conduct, the Vice President of Student Success/ Dean of Students, or his/her designee, may immediately intervene and impose sanctions, regardless of the regular procedure outlined in the Code of Conduct. This is especially true in cases where a student may be a danger to the campus community; in such cases, the Dean of Students, Assistant Dean of Engagement and Retention, or Vice President of Academic Services can and will immediately remove the student in question from the College community until the case is resolved.

Furthermore, the President of the College reserves the right to review and make final disciplinary decisions at any time during the disciplinary process. The Vice President of Student Success / Dean of Students or his/her designee is responsible for the coordination of judicial proceedings at the administrative level. Designees may include the V.P. for Academic Services or Assistant Dean of Engagement / Retention.

The College may approve revisions to the Student Code of Conduct. Those changes will be effective upon approval and will be posted in the Office of the Dean of Students. Each student is responsible for knowledge of the regulations and information contained in the Student Handbook. Therefore, students are encouraged to be attentive and alert to any announcements concerning changes to the rules and regulations governing student conduct.

Possible Alternative to Sanctions: Counseling

The Academic Dean, Judicial Board, and Vice President of Student Success/Dean of Students will be allowed to refer students to the on-campus Counselor. The Counselor will evaluate and possibly refer students who may need additional assistance from a human service agency. This may include a referral for alcohol and other drugs. Recommendations may be made in lieu of another sanction and may involve services at the cost of the student.

JUDICIAL BOARD

The Vice President of Student Success/ Dean of Students, in consultation with the Vice President for Academic Services, makes appointments to the college Judicial Board. The board shall consist of no less than three members, no fewer than two faculty or staff members and one non-voting student member, to hearing case. The Judicial Board hears disciplinary cases, upholds the College's values and policies, and affords due process.

Due Process of Judiciary Hearing for Student Code of Conduct Violation(s):

1. Violation reported and submitted to the appropriate office, Dean of Students, or V.P. of Academic Services.
2. Inform student in writing about receipt of report citing a possible violation and give details of timeline of inquiry and process.
3. Fact Finding: Conducted by the Dean of Students, V.P. of Academic Services, or designee.
4. Schedule an administrative meeting if the issue can be resolved administratively, or schedule a judiciary hearing if necessary
5. The appropriate V.P. will inform the student in writing about the details, location, time and date of the administrative meeting or judiciary hearing.
6. The appropriate V.P. will inform the student in writing about the judiciary's decision concerning the Student Code violations and mandatory sanctions.

Student Rights

Student who are involved with the College Judicial Board have the following rights:

- To receive a written description of charges pending against them and a notice of the hearing
- To attend the entire hearing, except during the deliberations
- The right to remain silent and the case will be determined on the evidence presented
- To respond to any charges against them
- To present evidence in their case
- To appeal any disciplinary action taken against them.

Due Process Rights

Students who are required to appear before the Judicial Board have the right to:

- The Presumption of innocence
- Be informed of their rights
- Have a written notice of the infraction within 24 hours
- Seek the advice of Student Government Association
- Be told what the maximum and minimum sanctions are
- Be made aware of the campus disciplinary structure
- Present factual defense through personal testimony and witnesses

Preponderance of Evidence

This means that the evidence shows that the facts sought are more probable than not. This

standard is used throughout the Student Conduct Code.

Evidence

In criminal court cases one must adhere to (a) formal rules of evidence. Rules that are related to State and Federal rulings will not be followed in campus judicial proceedings. Hearsay evidence on its own, cannot be used to administer sanctions, all evidence will be considered to make a decision on the case.

How do I appeal?

A student has the right to appeal a disciplinary action by the board. This is not a re-hearing process and should be filed within 24 hours, by the Judicial Appeals Officer. Appeal must be given to the Judicial Appeals Officer and a decision will be rendered in 24 hours by the Judicial Appeals Officer.

The appeal must include the reason for the appeal and what grounds justify an appeal. Please remember that appeals are only possible if a case has been referred to the Judicial Board. It is not the intent of Clinton College to present Judicial Board proceedings in an actual courtroom atmosphere. It is expected that students who are found responsible for violations will complete their sanctions and demonstrate conduct that is compliant with the Student Code of Conduct.

Students may appeal for the following reasons only:

- Procedural irregularity
- Proven bias by the board
- Evidence that the decision is unreasonable and does not support the evidence

The Judicial Appeal Officer

The position of the Judicial Appeals Officer will not be held by the Dean of Students nor the VP of Academics. The Dean of Students or designee will identify a faculty member or staff member to fulfill the position of Judicial Appeals Officer.

Urgency Cases

The Vice President for Student Success/ Dean of Students, after consultation with the Psychological Counselor and the Director of Residential Life, may take urgent measures to secure the health or safety of the student or other persons. Urgent cases include the following measures, but are not limited to:

- Immediate removal from the campus and or withdrawal from the college
- The Vice President for Student Success might request psychological assistance for the student, at the College or an outside facility at the student's cost.

Failure to Comply with Student Code of Conduct Sanctions

Students who are found responsible for violations and notified of their sanctions but fail to comply with them, will be considered in violation of the Student Code of Conduct (specifically with Failure to Comply) and are not entitled to a hearing on the charge that they have failed to comply with sanctions previously issued. An additional sanction will be applied by the Dean of Students without the benefit of a hearing.

STUDENT COMPLAINTS

Students have the right to file a complaint and seek remedies, based on Policy SS-2: Student Complaints (See Policy Manual). This section provides details on how to file a complaint.

Filing a Student Complaint

To understand the process of filing a complaint we recommend that you read the information below:

Policy Statement. Any student with a complaint, feels they have been treated unfairly will have the right to be heard fairly and promptly. The college recognizes that disputes may sometimes arise and require all parties involved to resolve the conflict informally. However, if resolution cannot be reached, the student can initiate the formal complaint process.

The Complaint Process

The complaint process is divided into an informal and formal process. This process is initiated by the student who will receive support and information during each of the four steps. A complaint may be resolved at various stages of the process. Complaints should be filed as soon as possible and no more than 90 days after the incident occurs. Students will receive an automatic notification via their Clinton College email account that their complaint has been received.

Filing an Informal Complaint

Step One. Try to resolve the matter by directly addressing the faculty member, staff member, or student. As a professional courtesy, students are advised to email the staff, faculty, or administrator with whom they have a complaint. Try to schedule a meeting. Keep in mind that initiating a casual hallway conversation or calling the person without first verifying their ability to speak with you could be unproductive and limit the opportunity to resolve the matter informally. Clearly present your concern to the person and remain open to their perspective, and ask how they might want to resolve the matter.

There may be some cases in which a student might feel uncomfortable directly addressing the person with whom you have a complaint. In these instance, the student should do the following:

- Contact the Vice President of Academic Services /Academic Dean in the case of a faculty member.
- Contact the Residential Life Director or Vice President for Student Success/ Dean of Students in the case of a staff member.
- Contact the Residential Life Director or the Vice President for Student Success/Dean of Students in the case of a student.

If a complaint or concern has not been resolved to the student's satisfaction, they may move into the formal complaint process listed below. If they have questions or would like assistance with this process, they should contact studentcomplaints@clintoncollege.edu.

Filing a Formal Complaint

Step Two. Students may utilize the formal complaint process after exhausting the informal complaint process. To submit a formal complaint, they must use the appropriate Clinton College Student Complaint Form found on the *Current Students* tab of the Clinton College website. This form can be submitted by email to studentcomplaints@clintoncollege.edu or, it can be printed and completed in writing and submitted to the Office of the Vice President of Student Success / Dean of Students in the Fisher Bldg.

After submitting a Student Formal Complaint Form, students will receive automatic notification via their Clinton College email account that it has been received. Based on the Vice President of Student Success findings, a decision will be made in writing to the student and the person alleged to have caused the grievance within (10) ten business days of receipt of the findings report. Students will be provided information regarding the next steps in the process and may be asked for additional information if necessary.

This step of the process, investigating complaints, will involve the faculty or staff member's Vice President or Staff Supervisor.

If a complaint or concern has not been resolved to the student's satisfaction, they may appeal the decision made by the Vice President or Staff Supervisor by continuing the complaint process into step three listed below. Questions can be directed at studentcomplaints@clintoncollege.edu.

Step Three: To appeal a decision made by the Vice President or Staff Supervisor with whom the student worked to resolve a complaint or concern, they must submit an email to: studentcomplaints@clintoncollege.edu stating their desire to appeal the current decision and provide the following information:

- Brief outline of steps already taken toward resolving the issue.
- Decision given by the Vice President or Staff Supervisor.
- Reason for appealing this decision.
- Possible solution(s) they suggest regarding the issue.
- Contact information (phone, email, etc.).

After the student's email requesting an appeal has been submitted, they will receive an automatic notification via their Clinton College email account that the complaint has been received. Based on the Vice President of Student Success findings, a decision will be made in writing to the student and the person alleged to have caused the grievance within (10) ten business days of receipt of the findings report. In this step of the process, the complaint now involves the faculty or staff member's Vice President/Dean. Decisions made by the Vice President/Dean can be appealed in Step 4 of the process.

Step Four: To appeal a decision made by the Vice President/Dean with whom the student worked to resolve a complaint or concern, they must submit an email to: studentcomplaints@clintoncollege.edu stating their desire to appeal the current decision and providing the following information:

- Brief outline of steps already taken toward resolving the issue

- Decision given by the Vice President/Dean
- Reason for appealing this decision
- Possible solution(s) they suggest regarding the issue
- Contact information (phone, email, etc.)

After the student's email requesting an appeal has been submitted, they will receive an automatic notification via their Clinton College email account that the complaint has been received. Based on the College President's findings, a decision will be made in writing to the student and the person alleged to have caused the grievance within (10) ten business days of receipt of the findings report.

In this step of the process, the complaint now involves the faculty or staff member's Vice President/Dean, and the College President. **Decisions made by the President are final and cannot be appealed.**

Confidentiality

In both informal and formal resolution processes, the student may request and will be assured of confidentiality in the investigation, resolution, and record-keeping about the complaint.

Record-Keeping

The responsible office for managing this policy, the Office of Student Success will securely maintain all confidential information and records of complaints, appeals, and proceedings. This office will also maintain and provide upon request the instructions for filing a complaint with TRACS and any other relevant government agencies.

Complaints to Outside Agencies

Clinton College makes every effort to resolve student complaints internally. The College expects all students to make efforts to resolve their concerns by adhering to steps outlined in this policy. If the student has exhausted all options to resolve a complaint within the College, the student may file a complaint with the State Accrediting Agency:

- South Carolina Commission on Higher Education
1122 Lady Street #300
Columbia, SC 29201

Instructions for filing a grievance with the state accrediting agency can be found online here: [Complaint Procedures and Form.pdf \(sc.gov\)](#)

Discrimination complaints may also be filed with the following federal and state agencies:

- [Home | Human Affairs Commission](#) South Carolina
- [US Department of Education Office for Civil Rights](#)
- [Equal Employment Opportunity Commission](#)

The student may also file a written complaint with the College's accrediting agency, the Transnational Association of Christian Colleges and Schools. Complaints to (TRACS) must be in writing and signed by the complainant. They should be sent to:

President
Transnational Association of Christian Colleges and Schools
15935 Forest Road
Forest, VA 24551

TITLE IX AND SEXUAL HARRASSMENT

Title IX of the Education Amendments of 1972 (“Title IX”) is a Federal civil rights law that prohibits discrimination on the basis of sex in education programs and activities. Under Title IX, discrimination on the basis of sex can include sexual harassment or sexual violence. Sexual violence means physical sexual acts perpetrated against a person’s will or where a person is incapable of giving consent, such as rape, sexual assault, sexual battery, and sexual coercion. See Policy GA-6: Title IX - Sexual Harassment Grievance in the Policy Manual for additional details.

Definitions

Actual Knowledge of Sexual Harassment, Sexual Misconduct and Interpersonal Violence:

The College receives actual knowledge of a sexual harassment, sexual misconduct or interpersonal violence (including sexual assault, dating/domestic violence, and stalking) incidents, as defined by the Title IX regulations or university policies, when the incident is reported to the Title IX Coordinator or to any College official with authority to institute corrective actions.

Complainant: An individual who is alleged to have experienced conduct that could constitute sexual harassment, sexual misconduct, or interpersonal violence, as defined by the Title IX regulations or other College policies.

Formal Complaint: A formal complaint is a document filed by a complainant with the university requesting that the College investigate the allegation of sexual harassment, as defined in this interim policy. In some cases, the Title IX Coordinator may file a signed formal complaint to request that the College investigate an allegation of sexual harassment.

Respondent: A respondent is an individual who has been reported to have committed conduct that could constitute sexual misconduct and interpersonal violence, including sexual assault, dating/domestic violence, and stalking, as defined in this policy, or in other university policies.

Sexual Harassment: This policy adopts the following definition of sexual harassment to apply to all reported incidents:

- An employee of the College conditioning the provision of an aide, benefit, or service of the College on an individual's participation in unwelcome sexual conduct.
- Unwelcome conduct determined by a reasonable person to be so severe, pervasive, and objectively offensive that it effectively denies a person equal access to the College’s education program or activity; or
- Sexual assault, as defined in 20 USC 1092 (f)(6)(A)(v); dating violence as defined in 34 USC 12291(a)(10); domestic violence as defined in 34 USC 12291(a)(8); or stalking as defined in 34 USC section 12291 (a) (30).
 - a. **Sexual Assault.** An offense that meets the definition of rape, fondling, incest, or statutory rape as used in the FBI's Uniform Crime Reporting system.

- i. A sex offense is any sexual act directed against another person, without the consent of the victim, including instances where the victim is incapable of giving consent.
- ii. Rape: The penetration, no matter how slight, of the vagina or anus with any body part or object, or oral penetration by a sex organ of another person, without the consent of the victim.
- iv. Fondling: The touching of the private body parts of another person for the purpose of sexual gratification, without the consent of the victim, including instances where the victim is incapable of giving consent because of his/her age or because of his/her temporary or permanent mental incapacity.
- v. Incest: Sexual intercourse between persons who are related to each other within the degrees wherein marriage is prohibited by law.
- vi. Statutory Rape: Sexual intercourse with a person who is under the statutory age of consent.

b. Dating Violence. The term “dating violence” means violence committed by a person:

- i. who is or has been in a social relationship of a romantic or intimate nature with the victim; and
- ii. where the existence of such a relationship shall be determined based on a consideration of the following factors:
 - iii. The length of the relationship.
 - iv. The type of relationship.
 - v. The frequency of interaction between the persons involved in the relationship.

c. Domestic Violence

The term “domestic violence” includes felony or misdemeanor crimes of violence committed by a current or former spouse or intimate partner of the victim, by a person with whom the victim shares a child in common, by a person who is cohabitating with or has cohabitated with the victim as a spouse or intimate partner, by a person similarly situated to a spouse of the victim under the domestic or family violence laws of the jurisdiction receiving grant monies, or by any other person against an adult or youth victim who is protected from that person’s acts under the domestic or family violence laws of the jurisdiction.

d. Stalking

The term “stalking” means engaging in a *course of conduct* directed at a specific person that would cause a reasonable person to—

- i. fear for his or her safety or the safety of others; or
- ii. suffer substantial emotional distress.

Course of conduct means two or more acts, including, but not limited to, acts in which the stalker directly, indirectly, or through third parties, by any action, method, device, or means follows, monitors, observes, surveils, threatens, or communicates to or about, a person, or interferes with a person's property. Substantial emotional distress means significant mental suffering or anguish that may, but does not necessarily, require medical or other professional treatment or counseling. Reasonable person means a reasonable person under similar circumstances and with similar identities to the victim.

Procedures

Reporting

1. Students, College employees, or other individuals who believe that someone has been sexually harassed during participation in the College's programs or activities may make a report to the College's Title IX Coordinator.
2. If the individual making the report is the alleged victim ("Complainant" as defined in the Title IX Sexual Harassment regulation), or if the Complainant is identified by the individual making the report, the Title IX Coordinator will meet with the Complainant to discuss supportive measures that may be appropriate in the particular circumstances and explain the process for filing a formal complaint.
3. The College cannot provide an informal resolution process for resolving a report unless a formal complaint is filed.

Formal Complaint

1. A Complainant may file a formal written complaint requesting investigation of alleged Title IX sexual harassment. The written complaint must include basic information concerning the allegation of sexual harassment (*i.e.*, date, time, location, individual(s) who allegedly engaged in sexual harassment, description of allegation). Complainants who need assistance in preparing a formal written complaint may consult with the Title IX Coordinator.
2. In accordance with the Title IX regulations, the Title IX Coordinator must dismiss a formal complaint under this Title IX procedure if:
 - a) the conduct alleged in the formal complaint does not constitute sexual harassment as defined under the Title IX regulations and the Title IX Sexual Harassment policy; or
 - b) the conduct alleged did not occur within the scope of the College's education programs and activities, or
 - c) did not occur in the United States.
3. In accordance with the Title IX regulations, the Title IX Coordinator may dismiss a formal complaint if:
 - a) a Complainant withdraws the formal complaint or withdraws particular allegations within the complaint.
 - b) the Respondent is no longer employed by or enrolled in the College; or

- c) there are specific circumstances that prevent the College from gathering evidence sufficient to reach a determination regarding the formal complaint. However, if the conduct potentially violates other policies or laws, it may be addressed through other applicable Board policy/procedure.
4. If a formal complaint is dismissed under this Title IX procedure, the Title IX Coordinator will promptly and simultaneously send written notices to the parties explaining the reasons. The parties have the opportunity to appeal dismissals as outlined below.
5. In certain circumstances, the Title IX Coordinator may file a formal complaint even when the alleged victim chooses not to. Examples could include instances where the Respondent (person alleged to have engaged in sexual harassment) has been found responsible for previous sexual harassment; a safety threat within the College, or other alleged serious violations where pursuit of a complaint is warranted.
6. If the conduct alleged in a formal complaint potentially violates other laws or College policies, the College may address the conduct under another applicable policy/procedure.

Emergency Student Removal/Suspension

The College may direct the removal of a student from education programs and activities on an emergency basis during the complaint procedure:

1. If there is a determination, following an individualized safety and risk analysis, that there is an immediate threat to the physical health or safety of an individual arising from the allegations of sexual harassment. Examples of such circumstances might include, but are not limited to, a continued threat of violence or a threat of self-harm.
2. The Respondent will be provided notice of the emergency removal and will be provided an opportunity to challenge the decision either before or following the removal (this is an opportunity to be heard, not a hearing).

Employee Suspension with Pay

An employee may be suspended with pay during the complaint procedure as provided in College policies.

Notice to Parties Following a Formal Complaint

1. The Title IX Coordinator will provide to the parties written notice of the formal complaint and allegations of sexual harassment potentially constituting Title IX Sexual Harassment. The notice shall include:
 - Notice regarding the complaint procedure and the availability of an informal resolution process;

- Sufficient details known at the time (including identities of parties, if known; the conduct alleged; and the date and location of the alleged incident[s], if known), allowing sufficient time to prepare before any initial interview (not less than ten [10] calendar days);
 - A statement that the Respondent is presumed not responsible for the alleged conduct and that a determination of responsibility will be made at the conclusion of the grievance process;
 - Notice that the parties may inspect and review evidence directly related to the allegations;
 - Notice that the parties may each have an advisor of their choice (who may be an attorney);
 - Notice that knowingly making false statements or submitting false information in bad faith during the complaint process is prohibited and may result in disciplinary action; and
 - Notice of the name of the investigator, with sufficient time (no less than three [3] calendar days) to raise concerns of conflict of interest or bias.
2. If additional allegations become known at a later time, notice of the additional allegations will be provided to the parties.
 3. The Title IX Coordinator will discuss supportive measures with each party and oversee implementation of such measures as appropriate.

Informal Resolution Process

After a formal complaint has been filed, and if the Title IX Coordinator believes the circumstances are appropriate, the Title IX Coordinator may offer the parties the opportunity to participate in an informal resolution process to resolve the complaint without completing the investigation and determination process. Informal resolutions can take many forms, depending on the particular case. Examples include, but are not limited to, facilitated discussions between the parties; restorative justice; acknowledgment of responsibility by a Respondent; apologies; disciplinary actions against a Respondent or a requirement to engage in specific services; or supportive measures. Both parties must voluntarily agree in writing to participate in an informal resolution process, and either party can withdraw from the process at any time. The Title IX Coordinator must approve the terms of any informal resolution reached between the parties. If an informal resolution agreement is reached, it must be signed by both parties and the Title IX Coordinator. Any such signed agreement is final and binding according to its terms.

If an informal resolution process does not resolve the formal complaint, nothing from the informal resolution process may be considered as evidence in the subsequent investigation or determination. The parties will be advised that engagement in the informal resolution process is grounds for extension of the investigation timeline.

Investigation

1. The complaint will be investigated by a trained internal or external individual designated by the Title IX Coordinator, who will consult with the College's legal counsel concerning the handling and investigation of the complaint.

2. The Investigator may consult with the Title IX Coordinator during the investigation process.
3. If the complaint is against a College employee, rights conferred under any applicable College employment policies shall be applied to the extent they do not conflict with the Title IX regulatory requirements.
4. The Investigator will:
 - a. Meet with each party after they have received appropriate notice of any meeting and its purpose, with sufficient time to prepare.
 - b. Allow parties to have their advisor at all meetings related to the complaint, although advisors may not speak on behalf of a party or interfere with the process.
 - c. Allow parties a reasonable opportunity to identify witnesses and submit favorable and unfavorable evidence.
 - d. Interview witnesses and conduct such other activities that will assist in ascertaining facts (site visits, review of documents, etc.).
 - e. Consider evidence that is relevant and directly related to the allegations in the formal complaint.
 - f. During the course of the investigation, provide both parties with an equal opportunity to inspect and review any evidence that is obtained in the investigation that is directly related to the allegations in the formal complaint.
 - g. Prior to completion of the investigation report, provide each party and advisor (if any) the evidence subject to inspection and review, and provide the parties with ten (10) calendar days to submit a written response. Access to such evidence may be provided via file sharing software that does not permit copying or downloading. The Investigator shall advise the parties that evidence is not to be publicly disseminated.
 - h. Consider the parties' written responses to the evidence prior to completing the investigation report.
 - i. Create an investigative report that fairly summarizes relevant evidence obtained during the Investigation. The Investigator shall send the report to the parties and advisors (if any) for their review and written responses which must be filed with the Investigator within ten (10) calendar days of their receipt of the report.
 - j. After receipt of the parties' written responses (if any), complete a Final Investigative Report and provide it to the Title IX Coordinator. The Title IX Coordinator will then provide the Final Investigative Report to the parties along with pertinent information relating to the hearing process.

Title IX Hearings

Timelines: All deadlines below are counted in calendar days. In the event a deadline falls on a weekend or College recognized holiday, the deadline will be the next business day.

- A. The live hearing must not occur earlier than ten (10) calendar days after the parties are provided copies of the Final Investigative Report and access to all inculpatory and exculpatory evidence.

- B. For allegations involving individuals, hearing notices will be sent to Respondent's and Complainant's official College email addresses no less than five (5) calendar days prior to the hearing date. Failure to read and comply with the notice is not suitable grounds for an appeal.
- C. For registered student organizations, a hearing notice will be emailed to the organization's representative, typically the organization's president, on file with the College no less than five (5) calendar days prior to the hearing date. Failure to read and comply with the notice is not suitable grounds for an appeal.
- D. The Title IX Coordinator will designate a Decision Maker and schedule the hearing. The Decision Maker may be a College employee or a contracted individual or entity who has the required training to conduct Title IX hearings. In accordance with Title IX regulations, the Decision Maker will not be the Informal Resolution Facilitator, Investigator, or Title IX Coordinator. When scheduling the hearing, the Title IX Coordinator will consider the availability of Respondent, Complainant, their respective Advisors, and the Decision Maker.

Pre-hearing conference

At least three (3) days prior to the hearing date, Complainant, Complainant's advisor, Respondent, and Respondent's advisor must attend a prehearing conference with the Decision Maker. The prehearing conference will be held virtually by videoconference at the time agreed upon by the Decision Maker and participants. The purpose of the prehearing conference is to discuss the purpose of the hearing, hearing procedures, and to address any procedural or evidentiary issues.

The topics for the prehearing conference include, but are not limited to, the following:

- A. Purpose of the hearing;
- B. Notice of charge(s) of misconduct;
- C. Hearing procedures;
- D. Time estimates for the hearing;
- E. Special requests for the hearing (e.g., breaks, separate rooms, virtual hearing, etc.);
- F. Hearing expectations related to professionalism and decorum;
- G. Witnesses expected to be called for the hearing;
- H. Documents to be submitted at the hearing. Advisors must state whether the document(s) was provided to the Investigator. If the document(s) was not provided, the advisor must explain the circumstances why the document(s) was not previously provided;
- I. Conflict of Interest of the Decision Maker. Objections to the Decision Maker must be raised during the prehearing conference or at the beginning of the hearing. The Decision Maker will indicate on the record whether either party raised objections to the Decision Maker conducting the hearing;
- J. Submission of sexual predisposition, history, or reputation questions to the Decision Maker. The parties or their advisors must submit any questions related to the sexual predisposition, history, or reputation of the Complainant or Respondent to the Decision

Maker at least one (1) day prior to the hearing for the purpose of determining relevancy and whether they are permitted under the Title IX regulations. The Decision Maker will make a determination as to the relevancy of the questions based on Title IX regulations and notify the advisors at the beginning of the hearing.

Live Hearing Procedures

Location of Hearing: The College may conduct the live hearing with all parties physically present in the same geographic location or any parties, witnesses, or other participants may appear virtually as long as all participants can simultaneously see and hear each other.

Record of Hearing: The College will create an audio or audiovisual recording or transcript of any live hearing. Copies of the recording or transcript will be made available upon request to the Complainant and Respondent.

The Decision Maker will conduct the hearing according to the following procedures:

- (1) The Decision Maker is responsible for maintaining order and determining the sequence of events during a hearing. The Decision Maker may direct any person who fails to comply with procedures during the hearing or who disrupts or obstructs the hearing to leave the hearing. All questions of law, whether substantive, evidentiary, or procedural, will be addressed to, and ruled upon by, the Decision Maker.
- (2) Complainant and Respondent have the right to be assisted by an advisor. If a party does not have an advisor present at the hearing, the College will provide, without fee or charge to that party, an advisor of the College's choice who may be, but is not required to be, an attorney to conduct cross-examination on behalf of that party.
- (3) The hearing will be closed to the public. Complainant, Respondent, and their respective advisors are allowed to attend the entire hearing.
- (4) Witnesses other than the Complainant and Respondent will be excluded from the hearings, except for the period of their own testimony.
- (5) Given the nature of these incidents and the impact on the overall College community, it is presumed that the Respondent is not responsible for the alleged conduct until a determination regarding responsibility is made at the conclusion of the grievance process. It is the responsibility of the Decision Maker to determine whether by preponderance of the evidence that the Respondent committed Sexual Harassment or Sexual Misconduct as defined under the Title IX regulations.
- (6) The Title IX Coordinator, or their designee, will arrange the attendance of witnesses who are members of the College community, if reasonably possible. The parties are responsible for arranging the attendance of witnesses who are not members of the College community if they wish for such witnesses to testify.

- (7) Advisors may ask both parties and witnesses relevant questions. Only advisors may conduct cross-examination of the parties and witnesses and only relevant cross-examination and other questions may be asked. The Decision Maker is responsible for making the determination of relevance and will explain to the advisor asking cross-examination questions any decision to exclude a question as not relevant.
- (8) If a Complainant, Respondent, or any witness testifies on direct examination but does not submit to cross-examination, the Decision Maker must not rely on any statement of that individual in reaching a determination regarding responsibility.
- (9) Unless a party explicitly waives the privilege in writing, the Decision Maker will not allow questions or evidence constituting or seeking the disclosure of information protected under a legally recognized privilege.
- (10) Questions and evidence about Complainant's sexual predisposition or prior sexual behavior are not relevant unless (1) such questions and evidence about Complainant's prior sexual behavior are offered to prove that someone other than Respondent committed the conduct alleged by Complainant, or (2) if the questions and evidence concern specific incidents of Complainant's prior sexual behavior with Respondent and are offered to prove consent. This standard is mandated by federal regulations and preempts any contrary South Carolina law. Any line of questioning referring to a party's sexual history or prior sexual behavior must be submitted to the Decision Maker at least one day before the hearing.
- (11) The Decision Maker will issue a written determination that includes:
 - a. Identification of the allegations potentially constituting Sexual Harassment or Sexual Misconduct;
 - b. A description of the procedural steps taken from the receipt of the Formal Complaint through the determination, including any notifications of the parties, interviews with the parties and witnesses, site visits, methods used to gather other evidence, and hearings held;
 - c. Findings of fact supporting the determination;
 - d. Conclusions regarding the application of Title IX;
 - e. A statement of, and rationale for, the result as to each allegation, including a determination regarding responsibility;
 - f. A statement of any disciplinary sanctions;
 - g. A statement as to whether remedies designed to restore or preserve equal access to the College's education program or activity will be provided; and
 - h. The College's provisions for appeal.

- (12) If disciplinary sanctions are included in the written determination, the past disciplinary record of the Respondent may only be supplied to assist in determining a sanction and not to determine if the current incident constitutes a violation of the policy.
- (13) The Decision Maker's written determination will be provided simultaneously to both Complainant and Respondent.
- (14) The Title IX Coordinator is responsible for the effective implementation of any sanctions and remedies.
- (15) The Title IX Coordinator does not have the authority to overturn or modify the Decision Maker's findings of responsibility. Only the Appellate Decision Maker may overturn the Decision Maker's findings of responsibility.

Remedies, Discipline and Other Actions

Range of Remedies to Allow Equal Access to Complainant

1. Remedies are measures used to ensure that the Complainant has equal access to the District's education programs and activities following the Decision Maker's determination. Such remedies may include supportive measures, and may include other appropriate measures, depending upon the determination and the needs of the Complainant. The Title IX Coordinator is responsible for implementing remedies and providing needed assistance to the Complainant.
2. Range of Disciplinary Sanctions (Students)
The following is a non-exhaustive range of disciplinary sanctions that may be imposed when there is a determination that students are responsible for one or more violations involving sexual harassment: Suspension; expulsion; change in class or housing assignments; requirement to engage in education or counseling program; disqualification or modification of privileges to participate in sports or extracurricular programs; no-contact orders; prohibitions or limitations on presence on College property or at College-related events; disciplinary probation; and other disciplinary sanctions and interventions set forth in the College policy.
3. Range of Disciplinary Sanctions (Employees)
The following is a non-exhaustive range of disciplinary sanctions that may be imposed when there is a determination that employees are responsible for one or more violations involving sexual harassment: Requirement to engage in education or counseling program; no-contact orders; assignment alteration; prohibitions or limitations on presence on College property or at College-related events; private reprimand; public reprimand; suspension without pay; termination.

Appeals

The College President may serve as the Appellate Decision Maker and shall assign or arrange for the services of a trained Appellate Decision Maker if s/he chooses not to serve in that role. The Appellate Decision Maker cannot be the Decision Maker, Informal Resolution Facilitator, Investigator, or Title IX Coordinator.

The Appellate Decision Maker shall have authority to preside over the appeal process in a manner that allows Complainant and Respondent an equal opportunity to participate, including setting reasonable page limits, enforcing timelines, and limiting review on the record to allowable grounds.

The parties (Complainant and Respondent) have the opportunity to appeal a responsibility determination and dismissals of formal complaints. Appeals will be considered only on the following grounds:

1. A procedural irregularity that affected the outcome;
2. New evidence that was not reasonably available as of the date of the determination regarding responsibility or dismissal of the formal complaint, that could affect the outcome;
3. The Title IX Coordinator Investigator, or Decision Maker had a conflict of interest or bias that affected the outcome of the process; or
4. [For dismissals only] The Title IX Coordinator misapplied the dismissal procedures or Title IX regulations when dismissing the matter.

Appeal Steps

1. An appeal must be filed in writing within five (5) calendar days of the receipt of the determination decision or dismissal. Appeals after that deadline will not be considered. The written appeal must state the grounds and arguments for reversal or modification of the determination or dismissal.
2. Appeals must be filed with the Title IX Coordinator, who will submit the appeal to the Appellate Decision Maker. Parties initiating an appeal or seeking reversal or modification of a responsibility determination must explain the impact of any asserted error on the outcome and, in the case of new evidence, explain why such evidence was not available, summarize the evidence and explain how the party contends such evidence would have affected the outcome.
3. The Appellate Decision Maker shall notify the other party in writing of the appeal and include copies of the of the document setting forth the grounds and arguments in support the appeal. The other party shall have the option to file with the Appellate Decision Maker written arguments in response to the opposing party's appeal within five (5) calendar days of receipt of the appeal document. An untimely response will not be considered.
4. The Appellate Decision Maker shall conduct an impartial review of the appeal including consideration of arguments of the parties and the written record and may consult with the College's legal counsel in the decision-making process.

5. The Appellate Decision Maker shall issue a written decision describing the result of the appeal and rationale for the result and provide notice of the written decision simultaneously to the parties. The Decision may: affirm the determination or dismissal, reverse the determination or dismissal, or modify the determination in whole or in part.
6. The Title IX determination or dismissal is final when there is no timely appeal or on the date when the Appellate Decision Maker sends his or her decision to the parties. A determination that conduct is not Title IX Sexual Harassment does not prevent the imposition of sanctions consistent with other law or policy where the conduct is determined to be in violation of such other law or policy.

Records Retention

Records in connection with sexual harassment reports and the grievance process shall be maintained for a minimum of seven (7) years. The responsible office for managing this policy, the Office of Student Success will securely maintain all confidential information and records of complaints, appeals, and proceedings. This office will also maintain and provide upon request the instructions for filing a complaint with TRACS and any other relevant government agencies.

Assistance in filing a Title IX Harassment Complaint

If students have any questions or would like assistance with any portion of this process, they may contact studentcomplaints@clintoncollege.edu or visit the office of the VP of Student Success/Dean of Students.

Confidentiality

In both informal and formal resolution processes, the student may request and will be assured of confidentiality in the investigation, resolution, and record-keeping about the complaint.

Complaints to outside agencies

Clinton College makes every effort to resolve student complaints internally. The college expects all students to make efforts to resolve their concerns by adhering to steps outlined in this policy. If the student has exhausted all options to resolve a complaint within the College, the student may file a complaint with the State Accrediting Agency:

South Carolina Commission on Higher Education
1122 Lady Street #300
Columbia, SC 29201

Instructions for filing a grievance with the state accrediting agency can be found online here: [Complaint Procedures and Form.pdf \(sc.gov\)](#)

Discrimination complaints may also be filed with the following federal and state agencies:

- [Home | Human Affairs Commission](#) South Carolina
- [US Department of Education Office for Civil Rights](#)
- [Equal Employment Opportunity Commission](#)

The student may also file a written complaint with the College's accrediting agency, the Transnational Association of Christian Colleges and Schools. Complaints to (TRACS) must be in writing and signed by the complainant. They should be sent to:

President

Transnational Association of Christian Colleges and Schools

15935 Forest Road

Forest, VA 24551

SAFETY PLAN



Clinton College seeks to provide a safe learning, work, and living environment for the entire campus community. To that end, the Office of Public Safety which is supervised by the Department of Building and Grounds, in consultation with the Department of Residence Life and the Office of Dean of Students is the first line of contact in any emergency.

Any person in immediate danger due to a crime or emergency should contact local police immediately by dialing 911. When the emergency has subsided, the victim should also report the crime as soon as possible to the Office of Dean of Students, Residence Life, and the Office of Public Safety. Local police have the authority to enforce all applicable regulations and laws. Residence Life personnel work closely with the local and state police concerning on-campus incidents. The Campus Alert System is used to contact all students, faculty, and staff if there is an immediate danger, harm, or disaster. Notifications are sent via text, telephone call and email.

Emergency Campus Alerts

Campus Alerts® is the premiere emergency messaging platform for colleges and universities. The system allows administrators to send real-time emergency messaging to students, faculty, and staff. Campus Alerts® is the most trusted emergency messaging service for Higher Education, school safety, and student notification in any situation. Students, faculty, and staff will receive an email, phone call to home and cell phone numbers, and a text message in the event of an emergency. This will occur in a real-time emergency. Recipients should adhere to the instructions of the relayed message.

Protocol to Initiate a Campus Alert emergency:

1. College President
2. Vice President for Academic Services/Academic Dean
3. Vice President for Enrollment Management and Student Success
4. Vice President for Business Services
5. Vice President for Institutional Advancement

Fire Plan:

The residence halls, administration/classroom building, library, student recreation center, and cafeteria are of masonry construction and have minimal structural vulnerability to fire. The Early Childhood Education building and Art Building are of frame construction but are equipped with two exits each, are single story, and have low traffic patterns. All buildings are equipped with multi-purpose dry chemical fire extinguishers, which are inspected semi-annually. Additionally, the Slade Martin Hall is equipped with a pull-down fire alarm.

In the event of a fire, move immediately to the nearest exit. Notify public safety, campus officials, and/or call 911 immediately. Residence hall directors, faculty members or other staff members who witness a fire should immediately verify the presence and safety of all persons known to be in the building. **Under no circumstances should students or staff persons re-enter a burning building.** (Exit plans attached)

Hurricane/Tornado Plan:

Rock Hill is situated three hours away from the coast. Therefore, the College is not typically in danger from hurricanes. However, occasionally a particularly severe storm may pose some level of threat to the campus. In the event of a Hurricane Warning/Tornado Watch, classes and other activities are immediately cancelled. If it is safe to do so, all students and all campus personnel are to gather in the J. W. Martin Gymnasium as quickly as possible.

Those who are unable to make it to the J. W. Martin Gymnasium should find a safe place away from windows and glass doors until given an “all clear” signal. The Facilities Department will give the “all clear” command once the civil defense horn signals. The individuals who are giving directives in their respective buildings should not end the state of emergency until they hear from someone in the Facilities Department.

Those in the residence halls should take a pillow (to cover one’s face) into the hallway designated by the Residence Life Director and/or staff member and lie down on the floor. Those in the Trio building should gather in the restroom. Those in the Snipes Student Center should gather in the corridor away from windows. Those in the New Millennium Café should gather in the kitchen area behind the gray wall away from windows. Those in the Library should gather in the corridor hallway near the President’s office away from windows.

In the event the campus must be evacuated to higher ground, faculty, staff, and students will be transported to New Mt. Olivet AME Zion Church at 527 Dave Lyle Blvd S, Rock Hill, SC 29730.

Medical Emergency:

Clinton College does not currently house an infirmary on campus. In the event of a medical emergency, call 911 and contact the office of Student Development Counselor (8:30 a.m. – 4:30 p.m.) or the residence director if the emergency is after hours. If you are unable to contact the persons identified above, locate the nearest faculty or staff member. Do not move the injured or unconscious person. Stay with the injured or sick person until the ambulance arrives.

Other Emergencies:

In the event of break-in, violent attack, car/other accident, or other emergency, contact the following:

Security department (24 hours)	803-371-9665
Residence hall directors (24 hours)	803-909-8183 or 803-909-8184
Administrative offices (8:30am-4:30pm)	803-909-8150
Rock Hill Police Department	803-325-2500

For immediate assistance dial 911.

CPR Certified Personnel:

The following campus personnel are certified in CPR training. These persons are available to assist with situations that may occur on campus.

- Alvin Bush
- Darryl Frazier
- Telea Vinson
- Angelyne E. Brown
- Ashley Jones

To alert people outdoors, emergency sirens will sound repeatedly to indicate a problem. If you hear a siren, immediately tune your radio or television to a local primary station. If necessary, students, faculty, and staff will go to the nearest elementary school.

Local stations will carry emergency alert messages. Please follow the instructions given on the radio or television.

Emergency Services and information stations

WRHI AM 1340/FM 94.3	Rock Hill
WRHM FM 107.1	York County
Immediate danger or harm	911
York County Emergency Management	1-803-326-2300 (24 hours) www.yorkcountyoem.com

Rock Hill Police Department 120 E. Black Street, Rock Hill, SC 29730	1-803-329-7200
Piedmont Medical Emergency Medical Services	1-803-329-1115
Crime Stoppers of York County	1-877-409-4321
Poison Information Center (National) Charlotte Number	1-800-222-1222 1-704-355-4000
Crisis Intervention Helpline Treatment Management Service	1-866-522-2034
Duke Energy Emergency Rock Hill Water Department	1-800-777-9898 1-803-329-5500

Radio/TV stations for Campus Safety Plan

Local stations will carry emergency alert messages. Please follow the instructions given on the radio or television.

Radio

WRHI AM 1340/FM 94.3 Rock Hill WRHM FM 107.1 York County

Television

WSOC Spectrum – Ch. 4 Comporium – Ch. 104 AT&T U-verse- Ch. 9

WBTV Spectrum – Ch. 2 Comporium – Ch. 105 AT&T U-verse- Ch. 3

WCNC Spectrum – Ch. 6 Comporium – Ch. 106 AT&T U-verse – Ch. 36

CAMPUS EVACUATION PLAN

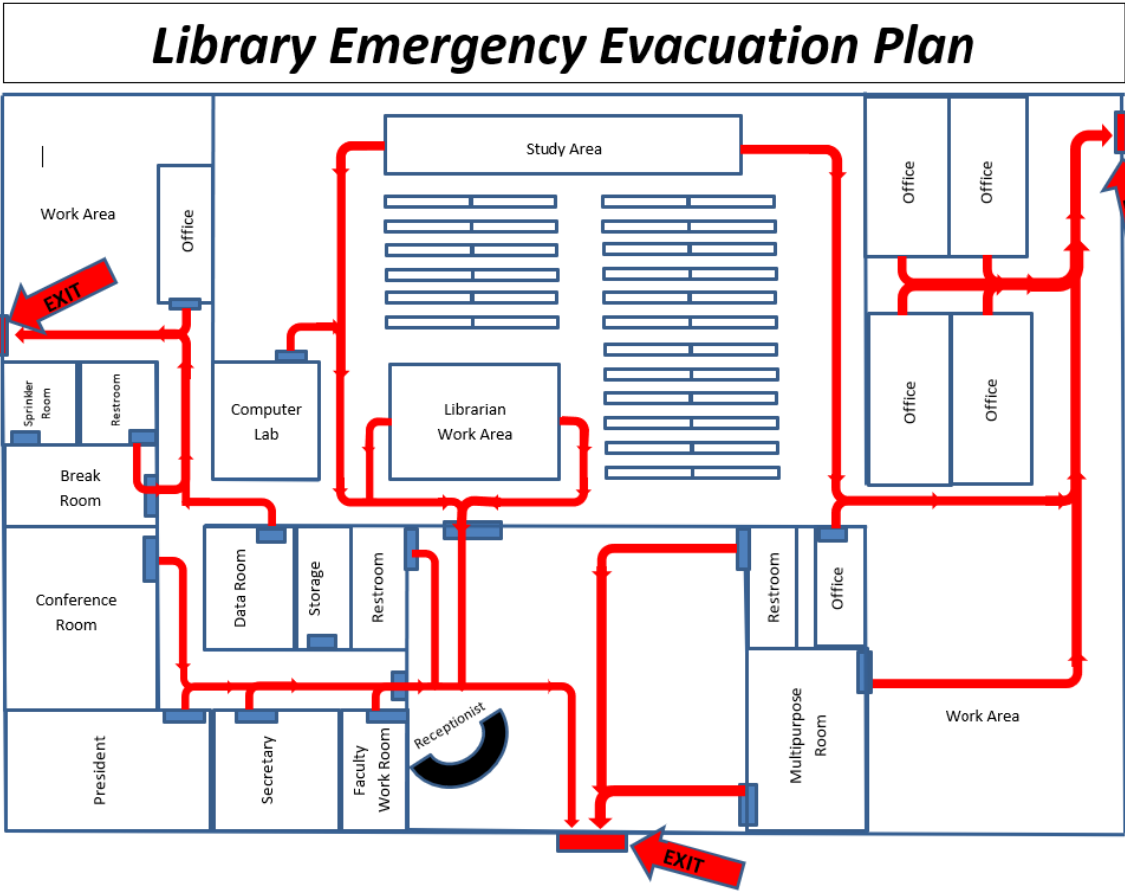

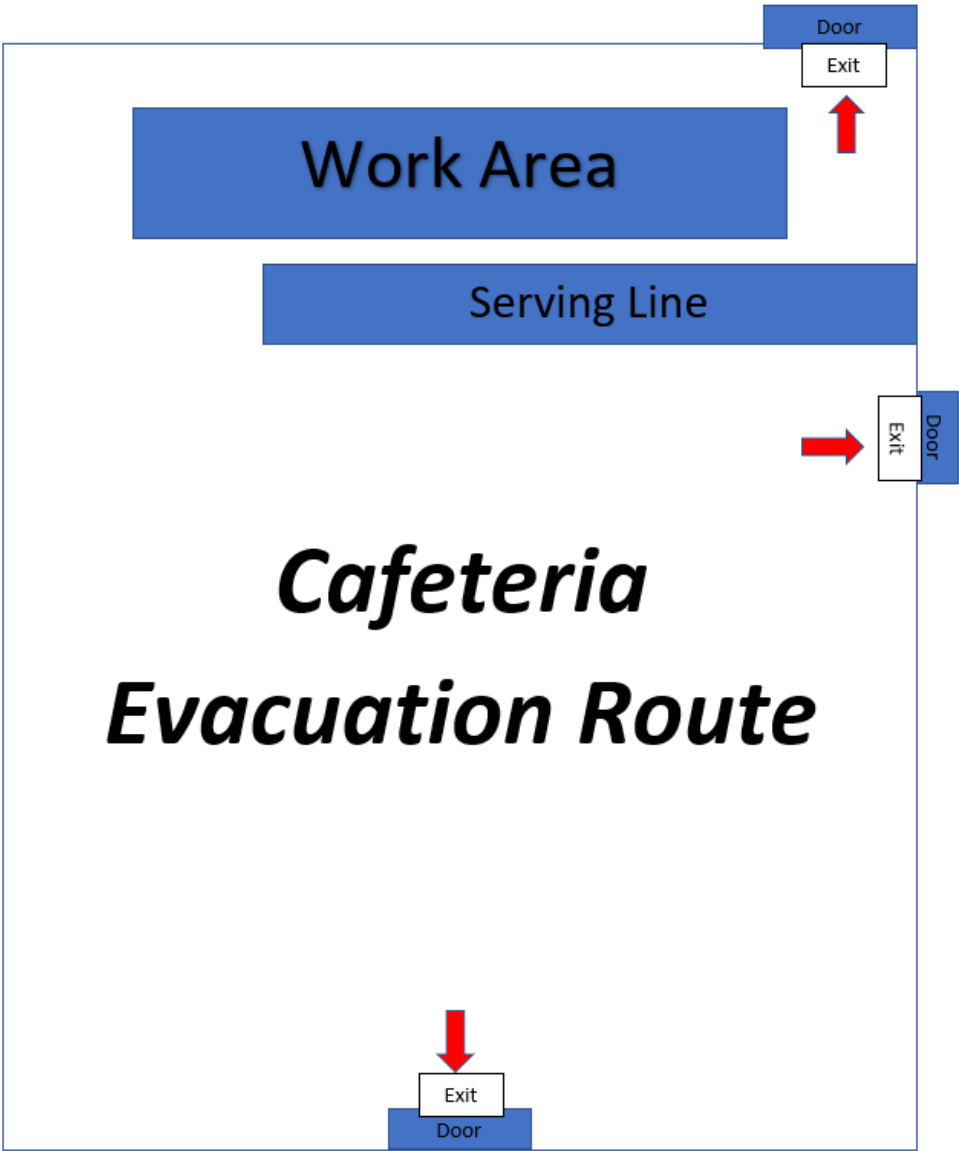

***Cafeteria
Evacuation Route***

Cauthen Hall Emergency Evacuation Plan

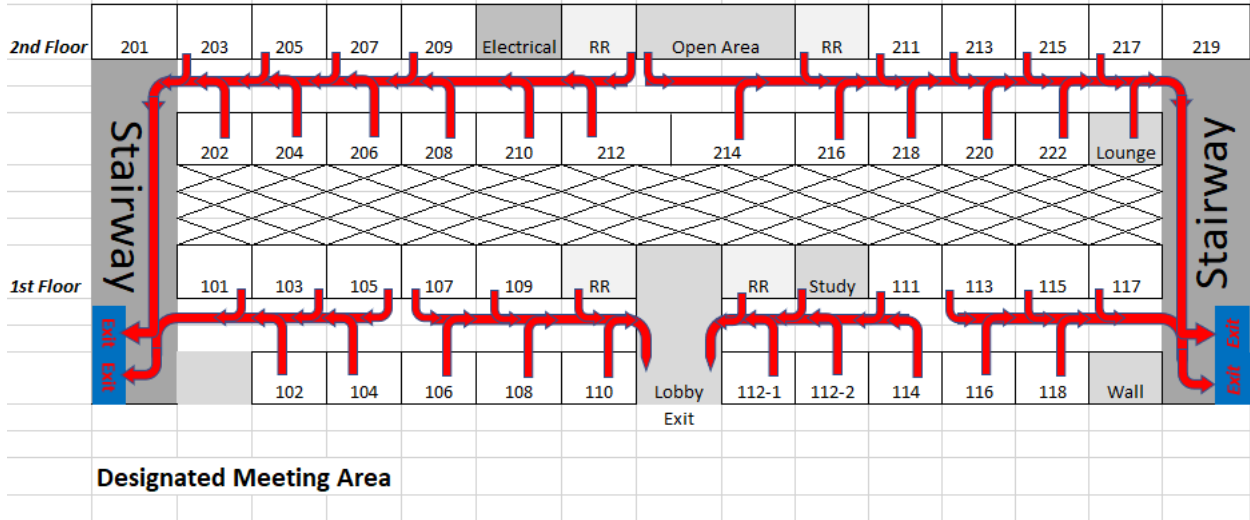

Marshall Hall Emergency Evacuation Plan

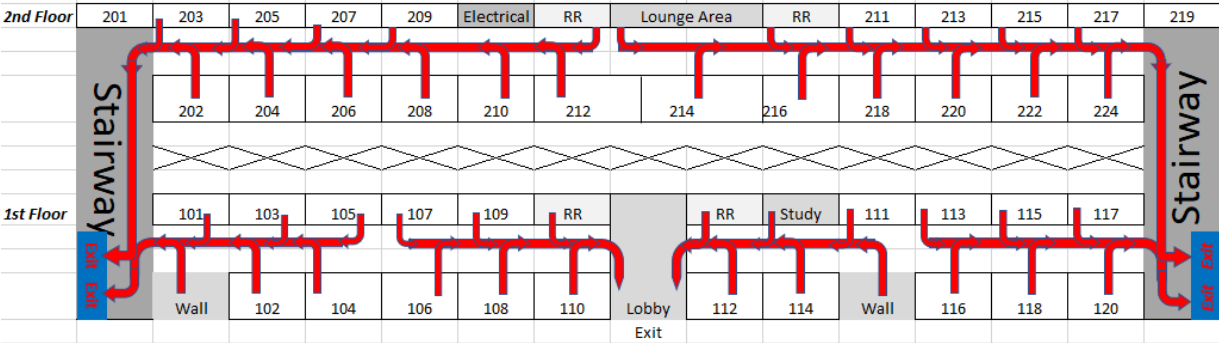

Designated Meeting Area

Fisher Building (TRIO) Emergency Evacuation Routes

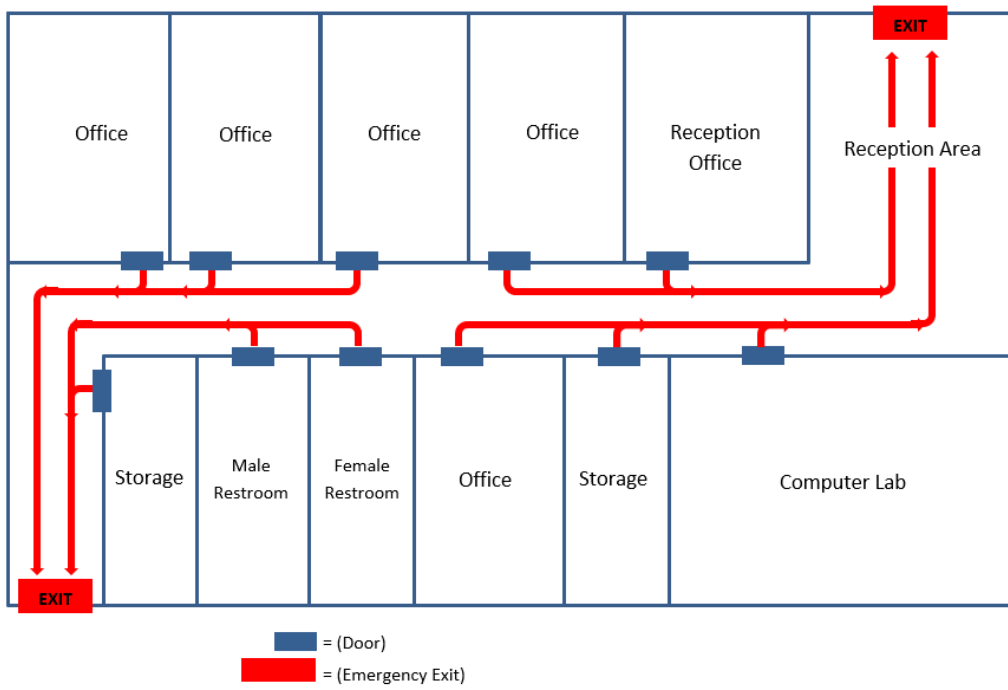

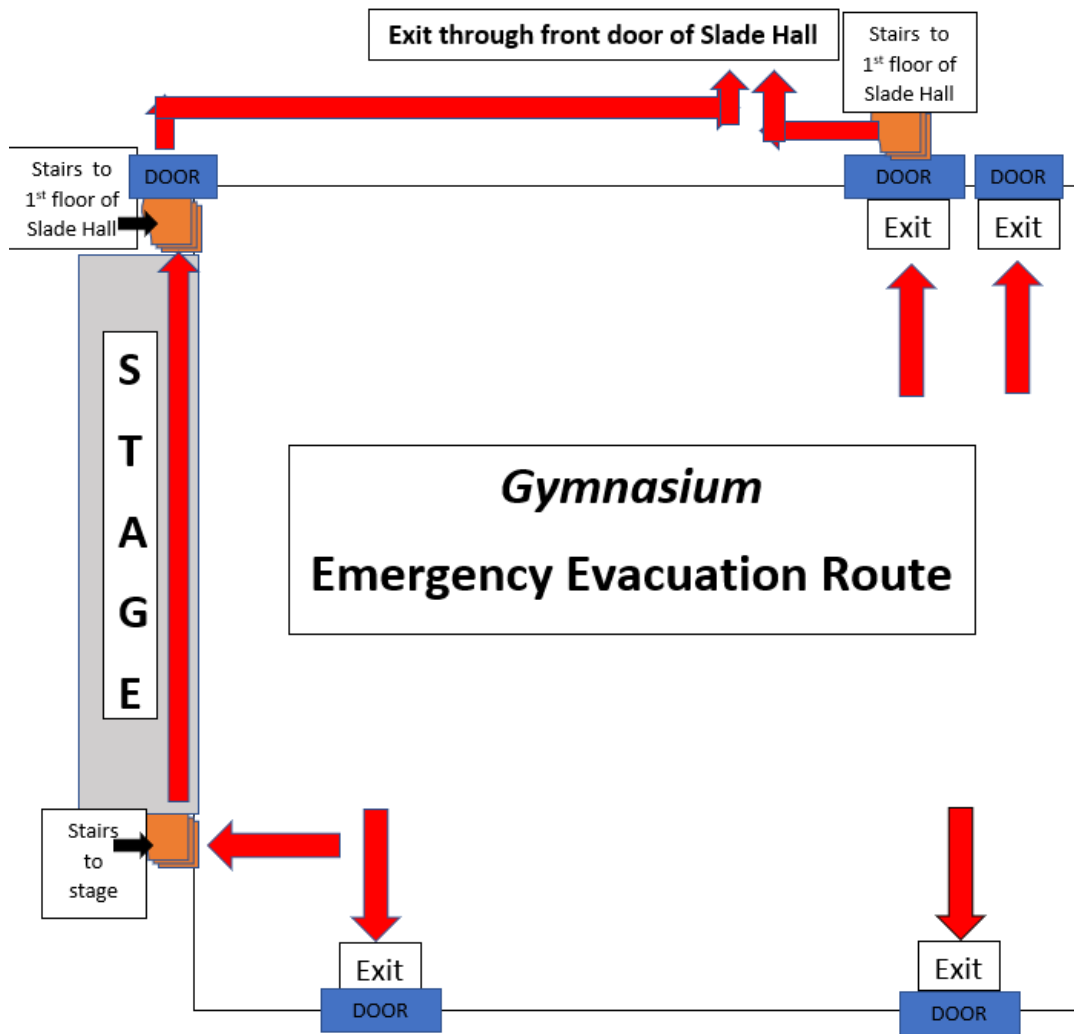

Slade Hall (1st Floor) Emergency Evacuation Routes

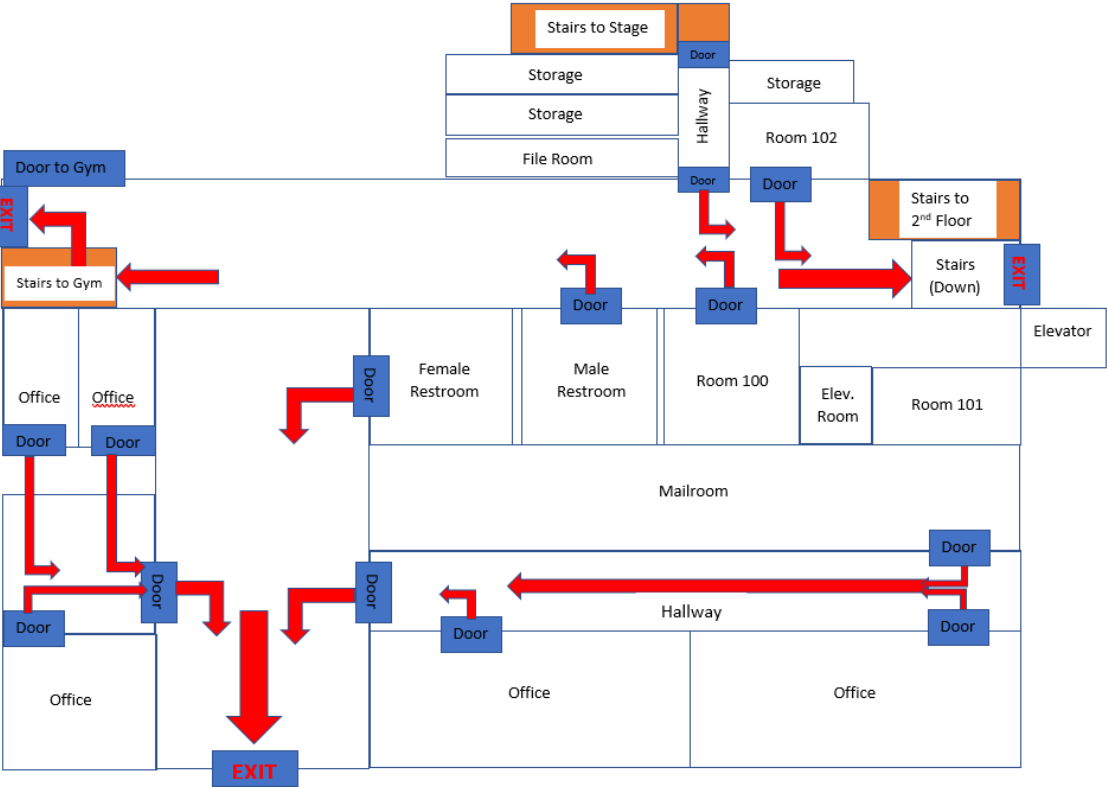

Slade Hall (2nd Floor) Emergency Evacuation Routes

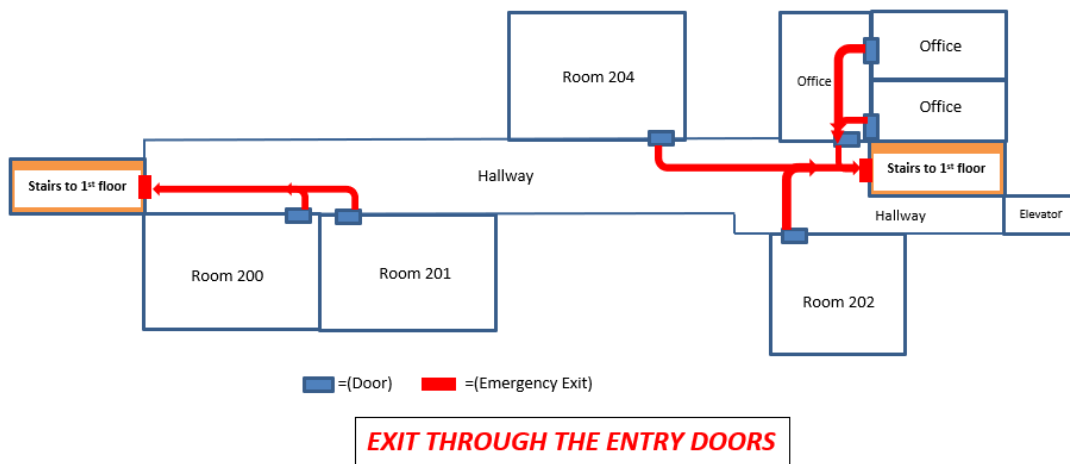

Snipes Student Center Emergency Evacuation Plan

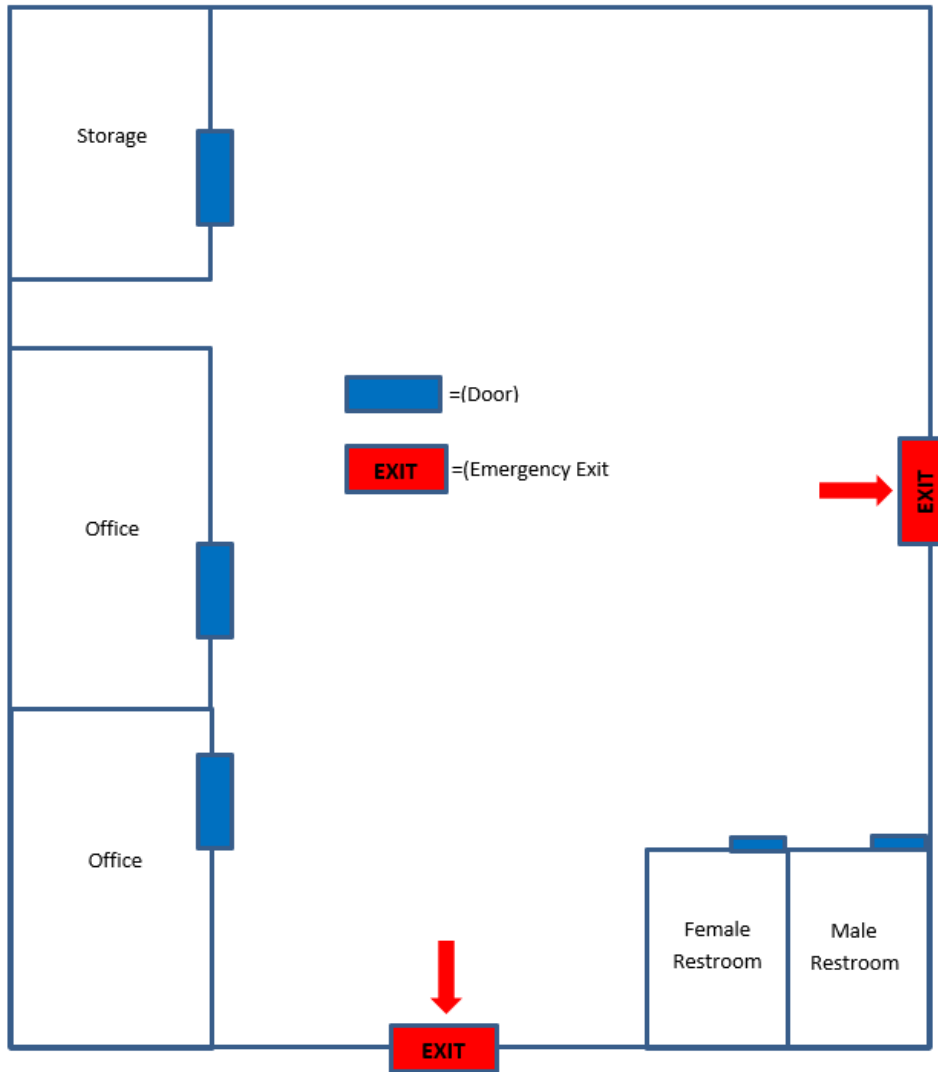

CRITICAL POLICIES



The Clinton College Policy Manual contains all official policies of the college and is available on the college website. The policies below are summarized or presented in their entirety because of their immediate importance to students. NOTE: They are referenced in other sections.

GA-3: Non-Discrimination Policy

Clinton College does not discriminate in admissions, educational programs, or employment on the basis of race, color, religion, sexual orientation or genetic information, national origin, age, disability, or veteran's status and prohibits such discrimination by its students, faculty, and staff. Students, faculty, and staff are assured of participation in college programs and in use of facilities without discrimination. The college also complies with all applicable federal and South Carolina statutes and regulations prohibiting unlawful discrimination. All members of the student body, faculty, and staff are expected to assist in making this policy valid in fact. See Policy GA-3: Non-discrimination Policy.

EEO/Title IX/Section 504 Statement. Clinton College does not discriminate on the basis of race, gender, color, religion, national origin, age, disability, or veteran status in the provision of educational opportunities, services, programs, benefits, and employment. In addition, the College does not discriminate on the basis of sex or disability in the educational programs and activities offered, pursuant to the requirements of Title IX of the Education Amendments of 1972, Pub. L./92- 318; and Section 504 of the Rehabilitation Act of 1973, and Pub. L. /93112, respectively. This policy applies to both employment and admission to the College.

GA-5: Family Right to Privacy (FERPA)

The Family Educational Rights and Privacy Act (FERPA) (20 U.S.C. § 1232g; 34 CFR Part 99) is a Federal law that protects the privacy of student education records. The law applies to all schools that receive funds under an applicable program of the U.S. Department of Education. FERPA gives parents certain rights with respect to their children's educational records. (See Policy GA-5: Family Right to Privacy) These rights transfer to the student when he or she reaches the age of 18 or attends a school beyond the high school level. Students for whom the rights have transferred are "eligible students." Parents or eligible students have the right to inspect and review the student's educational records maintained by the school. Schools are not required to provide copies of records unless, for reasons such as travel distance makes it is impossible for parents or eligible students to review the records. Schools may charge a fee for copies.

Parents or eligible students have the right to request that a school correct records that reflect inaccurate or misleading information. If the school decides not to amend the record, the parent or eligible student has the right to a formal hearing. After the hearing, if the school still decides not to amend the record, the parent or eligible student has the right to place a statement with the record setting forth his or her view about the contested information.

Generally, schools must have written permission from the parent or eligible student in order to release any information from a student's education record. However, FERPA allows schools to disclose those records, without consent, to the following parties or under the following conditions (34 CFR § 99.31):

- Institutional officials with legitimate educational interest;
- Other post-secondary institutions to which a student is transferring;
- Specified officials for audit or evaluation purposes;
- Appropriate parties in connection with financial aid;
- Organizations conducting certain studies for or on behalf of the institution;
- Accrediting organizations;
- To comply with a judicial order or lawfully issued subpoena;
- Appropriate officials in cases of health and safety emergencies; and
- State and local authorities, within a juvenile justice system, pursuant to specific State law.

Schools may disclose, without consent, "directory" information such as a student's name, address, telephone number, date and place of birth, honors and awards, and dates of attendance. However, schools must tell parents and eligible students about directory information and allow parents and eligible students a reasonable amount of time to request that the school not disclose directory information about them. Schools must notify parents and eligible students annually of their rights under FERPA. The actual method of notification (e.g., letter, inclusion in a PTA bulletin, student handbook, or newspaper article) is left to the discretion of each institution.

HS-1: Health Policy

It is the policy of the College to ensure the health, safety and welfare of its employees, students, contractors, visitors, customers, and others who may be affected by its operations. The College believes that effective management of health and safety is an essential part of its business strategy and is fully committed to providing the highest standards of health and safety at work. Legal obligations under the Health and Safety at Work etc. Act 1974 and associated regulations will be met by the College as far as is reasonably feasible. Attention will be paid to ensure:

- Safe and healthy work environments with identifiable (i.e. by sight or placards/sound) unobstructed access and egress
- Safe plant, equipment, and systems of work
- Safe handling, storage, and transport of potentially harmful articles and substances
- Information, instruction training, and supervision
- Adequate welfare facilities at work

It is the objective of the College to promote a positive health and safety culture in all of its activities and through instruction in courses taught. All employees have a duty to take reasonable care of their own health and safety and that of others who may be affected by their acts or omissions and to co-operate with the College in meeting its statutory requirements. In addition, all persons have a duty not to interfere intentionally with anything provided in the interests of health and safety.

In order to ensure the health, safety and welfare of employees, students, and others the College will make suitable and sufficient assessment of the risks associated with its activities and take appropriate preventative and/or protective measures.

The College considers the active involvement of its employees and students to be vital in achieving these objectives. Therefore, the College will consult with its employees through appropriate employee safety representatives and committees on all matters affecting their health, safety, and welfare.

The College will monitor and periodically review its safety policies, procedures to ensure they are appropriate and relevant. In order to help achieve objectives related to providing a safe environment the College will ensure it has provision for competent advice and guidance on health and safety matters.

Policies and Procedures will be revised annually at the end of the spring semester of each year. Current information will be added as deemed appropriate.

Assistance will be sought from community agencies to determine if all safety concerns are addressed. The safety plan will also be available via Clinton's home webpage, Policies and Procedures Manual, and Employee Manual.

Immunization

The South Carolina State Law requires that all our students provide a complete and accurate immunization record in order to be enrolled in college.

Insurance

Any full-time student must have health insurance or show evidence of insurance during enrollment.

Declaration of a Communicable Disease Emergency

The State Health Director and the Governor have authority to declare a public health emergency. In the case of a communicable disease emergency, the Governor has broad power to issue an emergency order to protect the public health.

Responsibilities

The College is responsible for monitoring and communicating guidance from local and State officials. In the absence of an order from the Governor, the President or his/her designees may review information from local or state public health officials to determine the severity of the situation and what actions should be taken, including the closure of the College. The College will adhere to any communicable disease orders established by the state or local public health agencies to prevent transmission of a communicable disease and will provide any supplies deemed necessary to protect students and employees. The College will also provide protective supplies to employees whose work assignments require such supplies. Students and employees are responsible for the following:

- Adhering to the College's operational protocols in response to the communicable disease emergency
- Communicating to the College any evidence of a communicable disease that could seriously endanger the health of others

Once notified, the Safety Compliance Officer, will immediately notify the appropriate administrators and/or health officials.

Possible Actions During a Communicable Disease Emergency

In the case of a communicable disease or other public health emergency, the College may modify its instructional methods and operations. Examples of such modifications include temporary suspension of courses, transitioning to online instruction, and implementation of temporary teleworking plans. Such emergency modifications will be communicated via student and employee communication platforms and the College's website.

College Closure and Campus Access Restrictions

When the College is closed due to a communicable disease emergency, employee access is limited to **essential personnel** unless prior authorization is granted. During a communicable disease emergency, students and employees should refer to the appropriate College response web page and corresponding resources for information on campus access, requirements, and protocols. The College may change these protocols as needed to reflect the changing nature of the emergency through the recovery period. Students and employees must comply with all on-campus

safety protocols, which are guided by Federal, State, and local decisions. Non-compliance with safety protocols will result in disciplinary action in accordance with the Student Code of Conduct and the employee Disciplinary Actions, Suspension, and Termination of Employment policy, respectively.

Vaccination and Testing Requirements

All Clinton College employees (full-time, part-time, **contractual**, and work-study students), **contractors, volunteers, and other individuals working on College premises**, will be required to submit proof of vaccination or proof of weekly testing, regardless of role or work location. Barring an acceptable exemption, refusal to comply with this requirement will result in disciplinary action in accordance with the Disciplinary Actions, Suspension, and Termination of Employment policy.

Student Employees

Students employed by Clinton College are considered College employees. Students employed under the work-study program are considered College employees if the work performed is for the College. Any work performed for any public or private agency, students are still considered College employees unless the agreement between the College and the organization specifying that the organization is considered the employer. Students considered College employees are subject to the vaccination and testing requirements outlined here.

New Employees and Volunteers

Finalists for employment will be notified during the interview process, and Human Resources will discuss the requirements with new employees during the onboarding process. Volunteers and other individuals working on College premises will be notified of the requirements during their initial discussion with their College point-of-contact.

Partnerships with External Settings

Individuals in roles that involve partnerships with external settings or organizations who are required to adhere to public health and safety laws and regulations may be subject to additional requirements.

Document Submission

Vaccinated employees, contractors, volunteers, and others working on College premises must submit a copy of their vaccination card via email to humanresources@clintoncollege.edu within ten **working days** of official notification from the College that proof of vaccination or proof of weekly testing is required.

Exemptions – The College recognizes that employees, contractors, volunteers, and others working on the campus might have medical or religious reasons for not complying with vaccination requirements. Individuals may submit an exemption request in accordance with the guidelines below for review and approval.

- ***Medical Exemption.*** Individuals who wish to request a medical exemption must submit a vaccination exemption request form and any supporting documentation from their medical

provider. ***Please Note: The College reserves the right to request additional supporting documentation.***

- Religious Exemption. Individuals who wish to request a religious exemption must submit a vaccination exemption request form and any supporting documentation. ***Please Note: The College reserves the right to request additional supporting documentation.***

Exemption requests will be reviewed by the Vice President for Business Services or their designee. The Vice President for Business Services or their designee will notify the requestor, and Human Resources of their determination in writing within ten working days of receipt of the request. If the request is denied, the requestor must comply with the vaccination or testing requirement within ten working days of notification, otherwise, they will be subject to disciplinary action. The exemption decision is final and not subject to appeal; however, individuals may submit a new exemption request if they can provide new or additional documentation to support their request.

Providing false information compromise the integrity of Clinton College's policies and procedures. Intentionally providing false information can cause irreparable harm to the College community. Accordingly, any individual who knowingly submits false vaccination, testing, or exemption information; or intentionally misleads College officials, will be subject to disciplinary action. Furthermore, the College reserves the right to report any related violations of state and/or federal law to the appropriate agencies.

Policy and Procedure Modifications

During communicable disease emergencies and other adverse conditions when normal operations are suspended, the College will implement a modified policy and procedure development process. The College also reserves the right to take the following actions:

- Authorize **official College communications** that supersede any other policy or procedure language if there is a conflict between the two
- Suspend existing policies and procedures to address emergent instructional and operational modifications
- Modify or suspend the standard policy and procedure development process when such modification or suspension is necessary to respond to the emergency in a timely manner
- Develop and implement new policies and procedures or revisions to existing policies and procedures when such action is necessary to reflect and address critical response efforts.
- Defer to the [President's authority](#) to adopt temporary policies or to amend or suspend existing policies for the duration of the emergent event.

Students or employees who know or suspect that a member of the College community has a communicable disease should immediately contact the Vice President for Business Services. During communicable disease emergencies, the College will notify students and employees of critical response updates and resources via student and employee communication platforms, the College's website, social media, and local media. Internal and External communications will be coordinated by the Director for Communications.

HS-4: Weapons Policy

The possession of firearms, ammunition, explosives, incendiary devices, or other weapons on the Clinton College Campus is prohibited. A “weapon” shall include anything likely to be used, or designed to be used, in destroying, defeating, or injuring a person or property damage; or an instrument by the use of which a fatal wound may include, but is not limited to, the following: any firearms, BB gun, pellet gun, ammunition, bow and arrow, cross-bow, slingshot, cross knuckles, knuckles of lead, brass or other metal, any bowie knife, dirk, dagger, or similar knife, or any knife having the appearance of a pocket knife, the blade of which can be opened by a flick of a button, pressure on the handle or other mechanical contrivance. (See Policy HS-4: Weapons Policy in the Policy Manual)

The possession of firearms, ammunition, explosives, incendiary devices, and other weapons anywhere on the Clinton campus is inconsistent with and seriously undermines the academic mission of Clinton College. Such possession creates a threat to the safety and welfare of students, employees, and visitors on the Clinton College campus, threatens the tranquility of the educational environment and contributes to an unacceptable climate of violence.

The following is also expressly included within the meaning of a “weapon” under this policy: (1) An unloaded firearm or gun of any sort, or (2) a harmless object that is instrumentally designed to resemble a firearm, explosive, or other weapon, which is used by or is in the possession of a person with the intent to cause fear or assault to another person.

Seeking Assistance

When in doubt about whether an item is a “weapon,” students are expected to contact the Clinton College Security or the VP for Business Services for assistance.

Exceptions to the policy

The only exceptions to this policy are as follows:

- Clinton College Security Officers
- Employees or consultants who are using the above items for institutional purposes and/or secured collections of weapons.
- To obtain approval to bring such items or collections to campus, The person requesting permission must contact the Office of Business Services.
- Any weapon brought for institutional purposes must be unloaded and locked or secured to render it unusable while on the Clinton College Campus. If there are any questions, the Vice President of Business Services should be contacted.
- Level I Peace Officers currently employed by other agencies must have valid credentials on their person. These credentials need not be displayed but must be presented upon request of a Clinton College Security Officer
- Persons doing security work must obtain prior approval from the Office of Business Services.

Failure to comply with Weapons Policy

This policy is intended to clearly state expected standards of personal conduct for employees, students, and visitors on the Clinton College campus. The consequences of any violation of this policy may include but are not limited to, the following actions:

- Termination and/or disciplinary action (faculty and staff)
- Suspension or expulsion (students)
- Removal from campus
- Designation of the violator as *persona non grata*
- Criminal or civil proceedings.

HS-7: Drug and Alcohol Abuse Prevention Program (DAAPP)

The purpose of the Clinton College Drug and Alcohol Prevention Program is to encourage responsible behavior; regulate the use of alcohol and controlled substances on Clinton College property; support state and local laws; provide a program of intervention, education, and support; and establish appropriate judicial sanctions/employment decisions for those who violate the policy. The full DAAPP policy (Policy HS-7) is located on the Clinton College home webpage and is also emailed to all current, faculty staff and students.

Clinton College prohibits the manufacturing, distribution, dispensing, possession or use of controlled substances, alcohol, or illegal drugs on the campus, or in any area under the temporary or permanent control of Clinton College. Faculty, staff, students, or any Clinton College employee who violate the Alcohol and Drug Policy will face sanctions ranging from a written warning to expulsion/termination from Clinton College.

It is the goal of Clinton College to develop educated students for effective leadership and service in our society. All faculty, staff, and students at Clinton College share in the responsibility to maintain an environment that promotes a quality educational experience. The illegal use or abuse of alcohol or a controlled substance by faculty, staff or students, adversely affects our educational environment, and deteriorates the learning environment, that makes Clinton College a special community. Because we are a close campus community, the behavior of one student has an effect on all others.

This policy also recognizes that punishment without education, is not in alignment with the policy's mission to educate and raise awareness among our Clinton College community (faculty staff, students). Therefore, educational strategies are one of the major approaches to addressing violations. We further recognize that some members of our Clinton College community may need more assistance than the college can provide, and for this reason, in addition to written, warning, and fines; suspension, expulsion or termination are also included as sanctions.

Clinton College expects its students and employees to comply with all the requirements of federal, local, and South Carolina state law. As such, the unlawful possession, use, or distribution of illicit drugs and/or drug paraphernalia as defined in South Carolina and federal statutes are prohibited and subject the violator to disciplinary action by Clinton College as well as possible prosecution by local, state, and/or federal authorities. Federal laws, including those governing marijuana, preempt state law and, therefore, apply on Clinton College campus. Clinton College students or employees who disregard the various drug laws are responsible for their actions and are not immune from the legal process by virtue of their educational or employment status. They may also be separated from the institution.

Students who use or sell illegal or prescription drugs will be subjected to disciplinary action by Clinton College. If a Clinton College administrator receives reliable information or other evidence that a student has been or is currently involved in the trafficking of illegal or prescription drugs, or has been, or is in possession of associated paraphernalia, as to make this a reasonable presumption; criminal and civil authorities may be notified, and the student will be

temporarily suspend pending an investigation for permanent dismissal in accordance with the Student Handbook.

Students who are accused of placing illegal or prescription drugs in the beverages or food of others will be subject to the same disciplinary procedures as those accused of selling illegal drugs.

Disciplinary Procedures for Students

Clinton College is neither a police agency enforcing the law, nor a sanctuary protecting those who violate laws regarding alcohol or other drugs. Clinton College is vitally invested in maintaining a campus and educational environment that is conducive to physical and psychological safety, intellectual development, and personal maturation. Clinton College acknowledges its obligation to address violations of our drug and alcohol policy that come to its attention.

Although any alcohol-related violation is subject to disciplinary consequences, Clinton College is most urgently concerned with those behaviors and accompanying attitudes that threaten the physical or psychological safety or wellbeing of self or others, infringe upon the rights of others, or are otherwise disruptive to our campus community. Following established guidelines, The V.P. of Student Success or designee will determine disciplinary action resulting from conduct violations in accordance with the Clinton College *Code of Conduct*.

Sanctions administered to students for a violation of the alcohol and drug policies, (as stated in the code of conduct in the student handbook), depending upon severity and or repeat offenses may include warning letters, educational programming, community service, probation, removal from student housing, suspension, or expulsion. Students may also be required to appear in front of the Clinton College Judiciary Board; and criminal or civil authorities may be contacted. Students may also be expected to pay restitution for all damages occurring as a result of their behavior.

Clinton College Security Officers, Residence Life Staff, faculty, and all other administrators will note and report all alcohol violations that come to their attention whether observed at parties, during class, or other social events, in campus public spaces, or during routine “walk-throughs” of residence halls. All other members of the Clinton College community may call attention to suspected violations of the Alcohol and Drug Policy and are expected to play an appropriate role in enhancing the safety and well-being of members of the Clinton College community. Reports of violations or suspected violations of the Alcohol and Drug Policy will be made to the Director of Residence Life.

IA-3: Social Media Policy

The Department of Institutional Advancement's social media policy is designed to create a community where the college can share its accomplishments, academic programs, activities, and events with the college audience.

As social media becomes a primary source for higher-educational institutions to communicate with the public, be aware of the consequences when used improperly. Poor behavior on social media costs many people careers and educational opportunities. Make proper decisions if you choose to use social media at Clinton College.

Below is Clinton College's social media policy (Policy IA-3). To avoid potential issues and consequences, the social media policy must be followed at all times, by all users at Clinton College. Clinton College expects students, faculty, staff, and visitors to obey the *Terms of Service* when using social media sites.

Individual Posting on Social Media Sites:

- **Transparency.** Exercise transparency about your identity. If you are promoting Clinton College, disclose your relationship with the college.
- **Protect Your Identity.** Do not post personal information that hackers or scammers could use.
- **Truthfulness.** Be truthful. The Internet has made it easy for people to verify the accuracy and validity of any public, and oftentimes, private statements, data, or other information.
- **Language.** Use appropriate language and tone. Consider your words and how you use them when addressing someone. Language that threatens, harasses, insults, bullies, or intimidates another person will not be tolerated by Clinton College.
- **Respect for Difference of Opinions.** Respect the views of others, even if you don't agree.
- **College Log and Name.** Do not use the Clinton College logo or the College itself, to promote or endorse any product, cause, person, political party or candidate.
- **Branding.** Do not use the Clinton College shield, wordmark, or any other image on your personal websites.

Posting on Behalf of Clinton College

IMPORTANT: All social media sites representing the college must be approved and created by the Marketing & Communications department.

- Make sure social media accounts follow college policy and design. When posting on the College's social media site, refer to the College Branding Guide.
- **Maintain confidentiality.** Do not share confidential information, non-public strategies, student records or personal information without authorization.
- **Post only accurate information.** Have all the facts before communicating about Clinton College's history, services, and programs. When in doubt, refrain from responding until you receive the correct information.
- **Know and respect your audience.** Be responsible with your words. You are speaking on behalf of Clinton College.

- Do not post personal views. Clinton College social media pages are to be used to promote **the College and its programs**. Personal views should not be shared and do not represent the values of the college.

BS-9: Use of Information and Communication Technology Policy

It is the policy of Clinton College to maintain an environment that promotes ethical and responsible conduct in all network activities by staff and students. (See Policy BS-9.) It shall be a violation of this policy for any employee, student, or other individual to engage in any activity that does not conform to the established purpose and general rules and policies of the college's network. Within this general policy, Clinton College recognizes its legal and ethical obligation to protect the well-being of our students. To this end, Clinton College retains the following rights and recognizes the following obligations of its network:

- To track network use and to monitor fileserver space utilization
- Assume no responsibility or liability for files deleted due to violation of fileserver space allotments.
- To remove a user account on the network
- To monitor the use of online activities. This may include real-time monitoring of network activity and/or maintaining a log of Internet activity for later review.
- To provide internal and external controls as appropriate and feasible. Such controls shall include the right to determine who will have access to the College-owned equipment and, specifically, to exclude those who do not abide by Clinton College's acceptable use policy or other policies governing the use of school facilities, equipment, and materials.
- Clinton College reserves the right to restrict online destinations through software or other means.
- To provide guidelines and training on the acceptable use and policies governing online communications.

General User Responsibilities

Use of the electronic media provided by Clinton College is a privilege that offers a wealth of information and resources for research. In order to maintain the privilege, users agree to learn and comply with all of the provisions of this policy.

Staff and Faculty Responsibilities

Staff and Faculty members who supervise students, control electronic equipment, or otherwise have occasion to observe student use of said equipment, shall make reasonable efforts to monitor the use of this equipment and to assure that it conforms to the mission and goals of Clinton College. Staff and Faculty members should become familiar with the Internet and its use so that effective monitoring, instruction, and assistance may be achieved.

Student Responsibilities

Students are expected to use the College's technology safely, responsibly, and primarily for school/work-related purposes.

Any incidental personal use of the college's technology shall not interfere with College business and operations, the work and productivity of any College employee or student, or the safety and security of college technology. The College is not responsible for any lost or damage incurred by a student because of his/her personal use of the college's technology.

Acceptable Use

All use of the Internet must be in support of educational and research objectives consistent with the mission and objectives of Clinton College.

- Proper codes of conduct during electronic communication must be used. When using e-mail, extreme caution must be taken to avoid revealing personal information.
- Network accounts are to be used only by the authorized owners of the account for the authorized purposes.
- All communications and information accessible via the network should be assumed to be private property.
- Mailing list subscriptions will be monitored and maintained, and files will be deleted from the personal mail directories to avoid excessive use of fileserver hard-disk space.
- Exhibit exemplary behavior on the network as a representative of your school and community. Be polite!
- From time to time, Clinton College will make determinations on whether specific uses of the network are consistent with the acceptable use practice.

Unacceptable Use

- Revealing personal information about another person, including home address and phone number, is strictly prohibited.
- Any use of the network for commercial or for-profit purposes is prohibited.
- Excessive use of the network for personal business shall be cause for disciplinary action.
- Any use of the network for product advertisement or political lobbying is prohibited.
- Users shall not intentionally seek information on, obtain copies of, or modify files, other data, or passwords belonging to other users, or misrepresent other users on the network.
- No use of the network shall serve to disrupt the use of the network by others. Hardware and/or software shall not be destroyed, modified, or abused in any way.
- Malicious use of the network to develop programs that harass other users or infiltrate a computer or computing system and/or damage the software components of a computer or computing system is prohibited.
- Hate mail, chain letters, harassment, discriminatory remarks, and other antisocial behaviors are prohibited on the network.
- The unauthorized installation of any software, including shareware and freeware, for use on Clinton College's computers is prohibited.
- Use of the network to access or process pornographic material, inappropriate text files (as determined by the system administrator or building administrator), or files dangerous to the integrity of the local area network is prohibited.
- Downloading, copying, otherwise duplicating, and/or distributing copyrighted materials without the specific written permission of the copyright owner is prohibited, except that duplication and/or distribution of materials for educational purposes is permitted when such duplication and/or distribution would fall within the Fair Use Doctrine of the United States Copyright Law (Title 17, USC).
- Use of the network for any unlawful purpose is prohibited.

- Use of profanity, obscenity, racist terms, or other language that may be offensive to another user is prohibited.

Disclaimer

Clinton College cannot be held accountable for information that is retrieved via the network. Pursuant to the Electronic Communications Privacy Act of 1986 (18 USC 2510 et seq.), notice is hereby given that there are no facilities provided by this system for sending or receiving private or confidential electronic communications. System administrators have access to all mail and will monitor messages. Messages relating to or in support of illegal activities will be reported to the appropriate authorities.

Clinton College will not be responsible for any damages you may suffer, including loss of data resulting from delays, non-deliveries, or service interruptions caused by our own negligence or your errors or omissions. Use of any information obtained is at your own risk.

Clinton College makes no warranties (expressed or implied) with respect to:

- The content of any advice or information received by a user, or any costs or charges incurred as a result of seeing or accepting any information;
- Any costs, liability, or damages caused by the way the user chooses to use his or her access to the network.
- Clinton College reserves the right to change its policies and rules at any time.

SS-1: Students with Disabilities

The faculty and staff at Clinton College are committed to providing equal and equitable educational opportunities to all students. Under the Americans with Disabilities Act (ADA) a person with a disability is defined as:

"Any person who (1) has a physical or mental impairment which substantially limits one or more major life activities, (2) has a record of such impairment, or (3) is regarded as having such impairment."

The Americans with Disabilities Act states

"No qualified individual with a disability shall, by reason of such disability, be excluded from participation in or be denied the benefits of the services, programs, or activities of a public entity [college], or be subjected to discrimination by any such entity."

It is the policy of Clinton College to abide by ADA requirements and city inspection regulations for access to facilities and equipment.

The services for students with disabilities are designed to ensure full access to programs and services. The Americans with Disabilities Act of 1990 upholds and extends Section 504 of the Rehabilitation Act of 1973. Title III of the ADA states:

"No individual shall be discriminated against on the basis of disability in the full and equal enjoyment of the goods, services, facilities, privileges, advantages, or accommodations of any place of public accommodation by any person who owns, leases (or lease to), or operates a place of public accommodation. (42 USC 12182)." Clinton College does not discriminate on the basis of a handicap in violation of Section 504 and the regulations implementing it.

SS-6: Residency Requirements

Clinton College is a residential community; therefore, freshman and sophomore students are required to live in on-campus housing for two continuous semesters. The age limit for residing in the halls is 25 years old. The residential housing agreement is binding for an entire academic year. However, students who live within a 25-mile radius of Clinton College may apply to live at home and commute from their parents' or legal guardians' permanent address. Students must complete an Off-Campus Housing Release Form, attach a map-quest or google maps document verifying the distance is 25 miles or less to the College and complete the notarized authorization form that is attached to the On-Campus Housing Release Form. In addition, students participating in an academic program that requires them to be away from campus (internship, study abroad, etc.) may apply for a mid-year release. Students leaving the College at the end of the fall semester will be granted a mid-year release. (See Policy SS-6: Residence Hall Policies in the Policy Manual for additional details.)

Residing in the residence halls is a privilege, not a right. At any time, students may be required to secure off campus housing if their conducts warrants, and there is a disregard for campus and/or residential life rules. This determination can be made by the recommendation of the Director of Resident Life in consultation with the college's Judicial Board, or the V.P. of Student Success/Dean of Students.

Pregnancy. Title IX prohibits discrimination on the basis of gender, including pregnancy, in educational programs and activities that get federal funding. This ruling means that school must give all students who might be, are, or have been pregnant the same access to school programs and educational opportunities that other students have. College personnel will not tell students to drop out of classes or programs or change your educational plans due to your pregnancy.

Clinton College does not discriminate against a student because of pregnancy. A student should notify the Dean of Academic Affairs upon learning of her pregnancy. Instances where the student is a resident in the residence hall, the student should inform the Director of Residence Life as soon as she learns that she is pregnant. Confidentiality will be maintained, and the information will be released only if there is a need to know by other individuals. It is important that pregnant students seek medical treatment as soon as it is determined that she is pregnant.

Clinton College is concerned about the mental and physical health of its students realizing that a pregnancy can be very stressful. The college does not assume liability for the care of the student or any pregnancy related costs. The student must be solely responsible for any and all pregnancy related expenses. No medical resources are available through the college. Pregnant students may continue taking classes and engage in all other college activities if they choose to do so. Alternatively, the student may request a medical leave of absence until after the birth of the child. However, it is important that the student make arrangement for housing of the infant prior to delivery. Infants are not allowed to live on campus or visit the rooms of the residence halls. There may be instances during a student's pregnancy that campus housing is not adequate to meet the student's needs. If this should occur, The Vice President of Student Success/Dean of Students may recommend that the pregnant student move to an appropriate residence off campus. Students who choose to remain on campus must understand that the College does not assume any responsibility should an incident occur.

SS-7: Student Dress Code

Clinton College understands and fully supports students' right to self-expression. The College has an obligation to create a living and learning environment where all members of the College community are comfortable and free from offensive/inappropriate dress which unreasonably interferes with, denies, or limits someone's ability to participate in or benefit from the College's educational programs and activities. The dress code is designed to provide guidelines so that all students dress in a manner that is appropriate and respectful to themselves and the campus community and prepares them to meet the professional standards for dress in the workplace and the global society. (See Policy SS-7: Student Dress Code)

Classroom instructors, College administrators, and staff have the right to address policy violators and/or deny admission to students (and their guests) dressed in any inappropriate or prohibited attire. Clothing and personal appearance while on campus attending class or campus functions should be neat, respectful, and appropriate. Students who have questions regarding the attire for different functions or desire further clarification on what is considered casual, business, semi-formal, or formal attire should consult with the Office of Student Success. Students who choose not to comply with the dress code will be subject to following sanctions:

1. **First Offense.** Verbal warning and denial of entry or removal from class, campus event, or campus activity.
2. **Second Offense.** Written warning and denial of entry or removal from class, campus event, or campus activity.
3. **Third Offense.** Denial of entry or removal from class, campus event, or campus activity and referred to the Dean of Students who will determine additional sanctions.

The following are examples of appropriate attire for various events:

Event / Location	Dress Code
Classes Library College Offices Cafeteria Student Center	Casual or business casual
Convocation Graduation Founders Day	Business or business casual
Beacon Forum	Clinton college Blazers, dress, slacks, and shoes. NO jeans, sneakers, hats, slides, or flip flops

Career Fairs On-campus interviews	Business attire
Balls Galas	Formal and semi-formal attire
Recreational activities	Casual attire

Examples of *inappropriate* attire include but are not limited to the following:

Caps should be removed upon entering campus buildings. (This policy does not apply to headgear that is part of a religious or graduation ceremony, and cultural dress.)
Do-rags, sleep hair wraps, sleep bonnets, hair rollers, pajamas, house slippers, or visible under-garments should not be worn outside of the residence halls.
No clothing should be worn with lewd, offensive, or derogatory messages.

FA-12: Satisfactory Academic Progress Requirements for Financial Aid

Educational institutions are required by federal law to create and implement a Satisfactory Academic Progress (SAP) policy to ascertain student eligibility for Federal Student Aid (FSA). (See Clinton College Policy FA-12: Satisfactory Academic Progress.) Students must meet BOTH the qualitative and quantitative standards each semester to receive financial aid. There are several variables to be considered in determining a student's eligibility for FSA funds. All coursework is evaluated against these standards, including coursework completed during a period when you did not receive financial aid. To maintain SAP, a student must meet the following standards:

Qualitative Standards

Minimum GPA 2.0 or higher. The student's cumulative grade point average (GPA) must meet 2.0. Non-remedial coursework assigned a letter grade contributes to the cumulative GPA. Achieving a GPA of less than 2.0 will result in academic/financial aid warning for the next term of enrollment. During the warning period, the student must maintain a minimum GPA of 2.00 each term. The warning status will be removed when the student's cumulative GPA is 2.00 or higher. Warning status will change to ineligible status if the student earns less than a 2.0.

Grade	Range based on 100 points	Quality points, based on 4.0 system	Meaning of the grade
A+	97-100	4.00	Excellent, achievement of distinction
A	93 - 96	4.00	
A-	90 - 92	4.00	
B+	87 - 89	3.00	Good
B	83 - 86	3.00	
B-	80 - 82	3.00	
C+	77 - 79	2.00	Fair
C	73 - 76	2.00	
C-	70 - 72	2.00	
D+	67 - 69	1.00	Poor
D	63 - 66	1.00	
D-	60 - 62	1.00	
F	0 - 59	0.00	Failure, unsatisfactory achievement

Quantitative Standard: Pace of Progression

At least 67% of all credit hours attempted must have passing grades each academic year.

Completing less than 67% of the cumulative attempted hours will result in financial aid warning for the next term of enrollment. During the warning period, the student must complete all (100 percent) hours attempted. The warning status will be removed when the student completes 67% of their cumulative hours. Courses assigned a letter grade of A, B, C, D, F, I, S, U, W or WP count in quantitative and maximum time frame calculation, as do transfer credits accepted toward degree programs and any repeated coursework. For example, if a student takes 15 credit

hours each semester for a total of 30 credit hours in the academic year, he/she must complete at least 20 of the 30 credit hours to achieve the minimum pass rate of 67% for the academic year. This standard is often referenced as “pacing.”

Maximum Time Frame

Students who are receiving financial aid are expected to complete all requirements for a bachelor’s degree within a maximum timeframe of attempted program hours. A student reaches maximum timeframe after having attempted the credit hour equivalent to 150% of the program hours required for current degree or certificate. The student will be INELIGIBLE for Financial Aid if he/she does not finish the degree or certificate program within the maximum timeframe.

The pace of progress is calculated by dividing **cumulative** hours that have been successfully completed by the **cumulative** hours attempted. The 67% completion rate maintains a pace of progression toward the degree or certificate that ensures completion of the academic credential within the maximum time frame allowed. See examples below:

- For the Associate Degree programs, 150% of 61 credit hours = 91 credit hours
- For the Bachelor’s Degree programs, 150% of 121 credit hours = 181 credit hours

Effect of grades on qualitative and quantitative standards:

The table below shows the impact of grades on meeting the qualitative (GPA) and quantitative (pacing) standards:

Grades	Definition	Impact on GPA	Impact on pacing
A - C	Successful completion	Maintains GPA at 2.0 or above	Maintains pacing at 100%
P	Passing, successful completion	No impact on GPA	Maintains pacing at 100%
D	Poor completion	Will bring GPA below 2.0 if not offset with A’s and B’s	Maintains pacing at 100%
F	Failing	Will bring GPA below 2.0 if not offset with A’s and B’s	Will bring pacing below 100%. May bring pacing below 67% if not offset with successfully completed courses.
I	Incomplete	No impact on GPA	Will bring pacing below 100%. May bring pacing below 67% if not offset with successfully completed courses.
W	Withdrawal from a course after drop-add but before mid-term. (All W’s means withdrawal from	No impact on GPA	Will bring pacing below 100%. May bring pacing below 67% if not offset with successfully completed courses.

	school at any time after drop/add.)		
WP	Withdrawal passing from a course after mid-term, non-completion	No impact on GPA	Will bring pacing below 100%. May bring pacing below 67% if not offset with successfully completed courses.
WF	Withdrawal failing from a course after mid-term, non-completion	No impact on GPA	Will bring pacing below 100%. May bring pacing below 67% if not offset with successfully completed courses.

Repeating a course

A student may repeat a course when the grade was a D or F to attempt to earn a higher grade. The higher grade will be the one calculated into the GPA and therefore will improve the GPA to meet or exceed the qualitative standard for receiving federal financial aid. However, the repetition of the course will not count toward the required rate of successful course completion (pacing).

Transfer courses

Courses accepted in transfer must have been completed with a grade of C or higher. Transfer courses do not count toward the GPA at Clinton College and only counts towards the maximum timeframe. However, the number of credit hours transferred is a factor in meeting the escalating GPA requirement for the qualitative standard.

Readmitted students

Students who return to Clinton College after a period of absence must establish and maintain a cumulative GPA and pacing rate that meets the requirements in this Financial Aid standard in relationship to credit hours attempted

Changing majors

If a student changes their major, the credit hours taken under all majors will be included in the calculation of the attempted credit hours total, the GPA calculation and the maximum timeframe for degree completion. Students who reach the maximum timeframe without completing the degree or certificate program will be denied financial aid for a second program until the initial program is complete.

Enrollment status

A student must be enrolled at least half-time (6 semester credit hours) in courses that count toward his/her degree to receive financial aid from the Direct Subsidized/Unsubsidized and Direct PLUS Loan programs. The Pell grant does not require half-time enrollment.

SAP Evaluation Frequency

Satisfactory academic progress is monitored at the end of every semester. Outstanding grades may change or delay your SAP status decision. If you have been meeting SAP standards and then fail to meet GPA or pace requirements you will be given a warning semester. During the

warning semester, you may continue to receive financial aid, but you are expected to improve your academic standing and degree progress to meet SAP standards at the end of the semester.

If you do not meet the conditions of SAP at the end of the warning semester, you will be denied financial aid beginning the following semester. You must submit the SAP Appeal to request financial aid consideration. If your appeal is approved, you will be on financial aid probation.

Note: There is no warning period for students who have exceeded 150 percent of program requirements. If you have earned over 150 percent of the credits required for your program, you are not eligible for financial aid and must submit the SAP Appeal to request financial aid consideration.

Appealing Suspension of Financial Aid:

A student may appeal the loss of financial aid eligibility on the basis of a qualifying reason: injury or illness, the death of a relative, or other special circumstances. The appeal must explain why the student failed to make satisfactory progress (GPA and/or pacing), what has changed in the student’s situation that will allow the student to make satisfactory progress by the end of the next semester, and what the student plans to do differently in order to make satisfactory progress. The appeal will be considered by the Director of Financial Aid, the Vice President of Business Services, and the Vice President of Academic Services. If these mitigating circumstances exist, the student should appeal the **INELIGIBILITY** status using the table below as guidance:

Possible Circumstance	Suggested Documentation
Death in the family	Death certificate, obituary
Divorce or separation	Court documents, lawyer statement
Domestic violence	Court documents, restraining orders, police records
Crime victim	Legal documentation, police records
Physical and/or mental illness	Documentation from medical professional
Learning disability	Individualized Education Program (IEP), DAC letter
Babysitter/daycare issues	Daycare provider letter
Change in economic situation	Unemployment statement, proof of funding loss
Imposed residential changes	Eviction notice, legal papers
Imposed employment changes	Statement from employer
Improper grading practices	Hearing documents, communication from instructor
Unjust arrest or incarceration	Court documents
Involuntary call to military service	Official military orders
Jury duty/court appearance	Court documents
Physical and emotional stress	Documentation from medical professional
Ward of state/foster care issues	Municipal documents

Examples of Unacceptable Circumstances (included but not limited to):

Need for Financial Aid
Withdrawal to avoid failing grade
Too many courses attempted due to change in major
Repeating courses for better grade in order to be accepted into different major
Limited number of tests/assignments
Disagreement with instructor
Voluntary change in work hours

Appeal deadlines

A student may submit the SAP Appeal at any time; however, aid cannot be reinstated retroactively for a prior semester.

Approval of Appeal

If a student's appeal is approved, the student will be put on Financial Aid Probation for one semester. If the student fails the satisfactory progress check after the end of the probationary period, the student may only continue to receive aid if they are meeting the requirements of their academic plan.

Denial of Appeal

If a student's appeal is denied, the student will lose eligibility for financial aid, and will need to use alternative financial resources to attend Clinton College until they correct their hour and/or GPA/qualitative deficiency. If a student who is not eligible to receive financial aid registers for classes, that student is responsible for all charges.

Notification of SAP status

Student's will be notified via email to the Clinton College student email account if they fail to meet SAP standards. If all grades are not posted by the SAP evaluation period, the notification of SAP status may be delayed or changed.

If a student is approved after an appeal, the student will be notified via email to the Clinton College student email account. Appeals are reviewed on a rolling basis as they are submitted. Incomplete appeals will be denied. The College will attempt to notify the student of the appeal status within 15 days of appeal.

Reinstatement of Financial Aid

- A student deemed ineligible for Financial Aid may apply for reinstatement of financial aid, and placed on financial aid probation when one of the following conditions prevails:

- The ineligibility has been successfully appealed and the student has accepted an Academic Plan.
- The student has earned the minimum GPA and hours needed to meet the Satisfactory Progress of requirements and/or is adhering to the Academic plan.

The Office of Financial Aid will notify the student in writing when the SAP Appeals Committee makes a decision. The decision of the SAP Appeals Committee is final.

Academic plan

An academic plan, when followed, will ensure that a student will meet SAP standards within the specified timeframe. The academic plan will include the minimum requirements for students who are not meeting SAP guidelines. If a student fails the satisfactory progress check at the end of the probationary semester, the student may only continue to receive aid if the College can determine that the student is following the established academic plan. If the College determines that a student is not following the academic plan, the student will be denied financial aid. The student may file a new appeal if their circumstances have changed, and they wish to be considered for aid eligibility.

FA-13: Veterans' Benefits

Clinton College's Policy *FA-13: Veterans' Benefits* follows the guidelines for disbursement of Veteran's Benefits under Title 38: Section 3679(e) of the Veterans Benefits and Transition Act of 2018. This act provides educational assistance for covered individuals under Chapter 31: Veterans Readiness and Employment and Chapter 32: Post-9/11 GI Bill Benefits. Additional details of the policy are available in the Clinton College Policy Manual. Clinton College permits any covered individual to attend or participate in courses during the period beginning on the date on which the individual provides to the college a certificate of eligibility for entitlement to educational assistance under Chapter 31 or 33. The certificate ends on the earlier of the following two dates:

1. The date on which payment from the VA is made to the institution.
2. 90 days after the date the institution certified tuition and fees following the receipt of the certificate of eligibility.

Clinton College will not impose any penalty, including the assessment of late fees, denial of access to classes, libraries, or other institutional facilities, or the requirement that a covered individual borrow additional funds, on any *covered individual* because of the individual's inability to meet his or her financial obligations to the institution due to the delayed disbursement funding from VA under chapter 31 or 33. The covered individual must take the following actions in conjunction with the Office of Financial Aid:

1. Submit a certificate of eligibility for entitlement to educational assistance no later than the first day of enrolling in a degree or certificate program.
2. Submit a written request to use such entitlement.
3. Provide additional information necessary for proper certification of enrollment by the educational institution.
4. If the VA education benefit disbursement is less than the amount of the student's financial obligation to the educational institution, the student is responsible to pay the difference.